

Multi-Purpose Stand



CUSTOM PRODUCTS & SERVICES
 6286 Claude Way E, Inver Grove Heights, MN 55076-4435
 PH: 888-444-1202 (Toll Free) or 651-452-0113 Fax: 651-452-2264
 E-mail: Info@custom-products.com
 Website: www.custom-products.com

MULTI-PURPOSE STAND



Wide variety of accessories provide flexibility for custom layouts.



All components are assembled to the uprights with plastic knobs or installed with hooks.



Layout and position of components may be changed without using tools, allowing your system to evolve with your needs.



36" and 54" stands high can be made mobile for added flexibility.



WMA4050

MULTI-PURPOSE STAND

The multi-purpose stand allows you to keep a multitude of accessories close at hand, from the simplest tools to complex computer parts, spools supports and electronic equipment.

Both the centered and off-center stands give you fast access to each and every item you're storing. In addition to the stationary stands, available in 36", 54" and 84" high, Rousseau also offers a 36" and 54" high mobile version.

The accessory layout on the Rousseau multi-purpose stand is easily changed, without tools. Modify the stand according to your evolving needs by simply adding and moving the accessories.

Storekeeper Model



WMA1012

Makes transporting small items easy.

- 1 – 54" high centered WM stand
- 8 plastic bin rails
- 1 document holder
- 1 bottom shelf with ribbed matting

| Product # | W x D x H |
|-----------|---------------------|
| WMA101 | 32" x 27" x 59 1/4" |
| WMA131 | 38" x 27" x 59 1/4" |



WMA1052

Facilitates workstation and assembly line tasks.

- 1 – 54" high centered WM stand
- 2 tiltable shelves
- 6 partial dividers
- 1 bottom shelf with ribbed matting
- 2 tiltable pans

| Product # | W x D x H |
|-----------|---------------------|
| WMA105 | 32" x 27" x 59 1/4" |
| WMA135 | 38" x 27" x 59 1/4" |

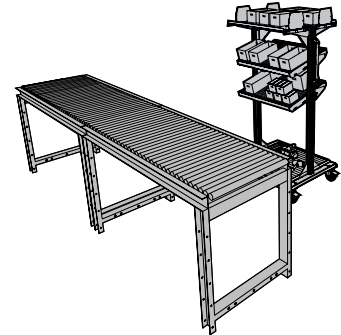

Wire Spool Model



WMA1032

Facilitates storing and access to wire spools.

- 1 – 54" high centered WM stand
- 1 bottom shelf with ribbed matting
- 8 wire spool supports

| Product # | W x D x H |
|-----------|---------------------|
| WMA103 | 32" x 27" x 59 1/4" |
| WMA133 | 38" x 27" x 59 1/4" |

"5S" Model



WMA1382

Multitasking model for storing each item in its proper place.

- 1 – 54" high centered WM stand
- 2 tiltable shelves
- 2 utility panels
- 1 bottom shelf with ribbed matting
- 4 plastic bin rails
- 2 tools supports
- 4 heavy-duty round hooks
- 2 heavy-duty square hooks
- 2 wire spool supports
- 2 can supports

| Product # | W x D x H |
|-----------|---------------------|
| WMA108 | 32" x 27" x 59 1/4" |
| WMA138 | 38" x 27" x 59 1/4" |

ATTENTION

TO ORDER: Model numbers must be completed according to the selected option.

Stationary models:

- 0 with floor anchoring kit
- 1 with leveling glide kit

Mobile models (54" high stands only):

- 2 with handle and 4" casters: 2 rigid and 2 swivel with total-lock brake system
- 3 with handle and 4" casters: 2 swivel and 2 swivel with total-lock brake system
- 4 with handle and 6" casters: 2 rigid and 2 swivel with total-lock brake system
- 5 with handle and 6" casters: 2 swivel and 2 swivel with total-lock brake system

NOTE Any and all accessories not mentioned in the description are not sold by Rousseau.



Proposals

Labeling Model

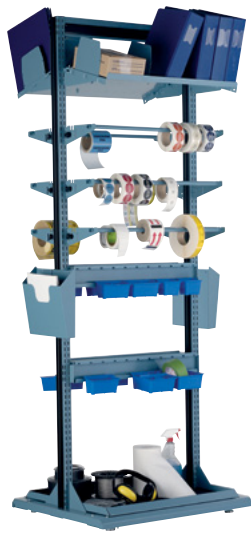

WMA3021

The perfect solution for all of your labeling needs.

- 1 – 84" high centered WM stand
- 2 tiltable shelves
- 6 partial dividers
- 4 plastic bin rails
- 6 wire spool supports
- 2 document holders
- 1 bottom shelf with ribbed matting

| Product # | W x D x H |
|-----------|-----------------|
| WMA302_ | 32" x 27" x 85" |
| WMA332_ | 38" x 27" x 85" |

Repair and Maintenance Model



WMA3031

For repair or maintenance tasks on workstations installed back-to-back.

- 1 – 84" high centered WM stand
- 2 cantilever overhead supports
- 2 overhead workstation lights
- 2 tiltable shelves
- 6 partial dividers
- 2 perforated panels
- 1 panel bracket kit
- 2 packs of 10 double back single hooks
- 2 wire spool supports
- 2 vertical adaptors for electrical and air outlets
- 2 power outlet strips
- 2 document holders with arm

| Product # | W x D x H |
|-----------|-----------------|
| WMA303_ | 32" x 27" x 85" |
| WMA333_ | 38" x 27" x 85" |

Electronic Model



WMA4041

Our proposal to organize and protect the equipment in an electronic workstation.

- 1 – 84" high off-center WM stand
- 1 cantilever overhead support
- 1 overhead workstation light
- 1 plastic bin rail
- 1 storage cabinet with door and lock
- 6 partial dividers
- 1 tiltable pan
- 1 vertical adaptor for electrical and air outlets
- 1 power outlet strip
- 1 lamp with magnifier and fluorescent light
- 1 light-duty arm adaptor

| Product # | W x D x H |
|-----------|-----------------|
| WMA404_ | 32" x 27" x 85" |
| WMA434_ | 38" x 27" x 85" |

Computer Model



WMA4021

Complete workstation with all the space you need for your computer components.

- 1 – 84" high off-centered WM stand
- 2 tiltable shelves
- 6 partial dividers
- 1 bottom shelf with ribbed matting
- 1 tiltable pan
- 1 document holder with arm
- 1 vertical adaptor for electrical and air outlets
- 1 power outlet strip

| Product # | W x D x H |
|-----------|-----------------|
| WMA402_ | 32" x 27" x 85" |
| WMA432_ | 38" x 27" x 85" |

ATTENTION

TO ORDER: Model numbers must be completed according to the selected option.

Stationary models:

0 with floor anchoring kit

1 with leveling glide kit

NOTE Any and all accessories not mentioned in the description are not sold by Rousseau.



Components

Multi-Purpose Stand Stability and Capacity

LEGEND

Workstation stability is safe.

This configuration is not recommended.

54" STANDS

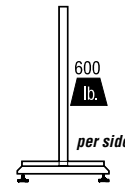

84" STANDS

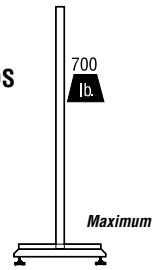

Maximum capacity : 1200 lb., evenly distributed load.



Maximum capacity : 700 lb. load distributed on one or both sides.

Multi-Purpose Stand

WMA

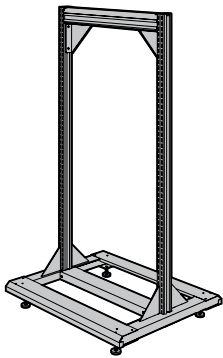

Stand available in 2 widths: 32" (28" c/c post) and 38" (34" c/c post);
Stand offered in three heights : 36", 54" and 84";
Centered and off-center stands available;
Post offers up to 6 fixing zones for a minimum of interference between components.
To order, please specify the width and models you want by referring to the table.

| Product # | Height | Type |
|-----------|--------|------------|
| WMA5_0 | 36" | Centered |
| WMA6_0 | 36" | Off-center |
| WMA1_0 | 54" | Centered |
| WMA2_0 | 54" | Off-center |
| WMA3_0 | 84" | Centered |
| WMA4_0 | 84" | Off-center |

TO ORDER:

- 0** for 32" wide (uprights 28" c/c)
- 3** for 38" wide (uprights 34" c/c)

EXAMPLE : **WMA5_0**

Stationary models:

- 0** with floor anchoring kit
- 1** with leveling glide kit

Mobile models (36" and 54" high stands only):

- 2** with 4" casters : 2 rigid and 2 swivel with total-lock brake system
- 3** with 4" casters : 2 swivel and 2 swivel with total-lock brake system
- 4** with 6" casters : 2 rigid and 2 swivel with total-lock brake system
- 5** with 6" casters : 2 swivel and 2 swivel with total-lock brake system

Replacement Handle

WS74

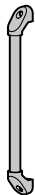

Aluminum with black plastic end caps;
Installs on the side of the multi-purpose stand;
Modern, attractive look;
Included with 54" H mobile models.

Product #
WS74-1202

4" and 6" Casters

LB81 / LB84

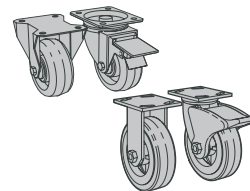

Choice of 3 types of casters : rigid, swivel, swivel with total brake (on wheel and swivel);
4" casters : 420 lb.; capacity; 5 1/4" high;
6" casters : 900 lb.; capacity; 7 1/2" high;
Heavy-duty, non-marking polyurethane casters; superior quality industrial casters;
Included with 36" H and 54" H mobile multi-purpose stands.

Shelf for WM Upright

WM84

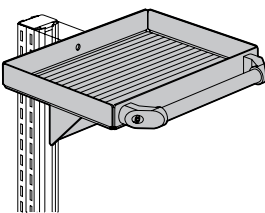

Usable shelf area : 8" x 14" x 1";
Horizontal aluminum handle with plastic end caps available for 36" high mobile stands only.

| Product # | Description |
|-------------|---|
| WM84-081401 | With handle for 36" high mobile stands |
| WM84-081402 | Without handle for 36", 54" and 84" high stands |

Document Holder

WM90

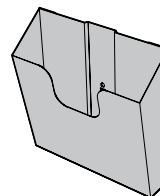

Specially designed to be installed on the multi-purpose stand;
Keeps paperwork or manuals accessible and organized.

Product #
WM90-01

Protective bumpers

WM92



"L" shape bumper fixed with 3 machine screws into nuts riveted to base WMA.
Sold in kits of 4.

Product #
WM92-01

Bottom Shelf

WM83

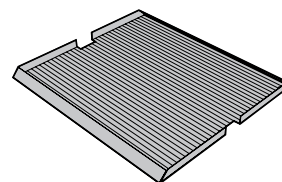

Fastened at the bottom of the multi-purpose stand;
Equipped with heavy-duty ribbed matting;
Dimensions: 26" W x 22 3/4" D and 32" W x 22 3/4" D (inside dim.)

| Product # | Structure |
|-------------|------------|
| WM83-282701 | Centered |
| WM83-282702 | Off-center |
| WM83-342701 | Centered |
| WM83-342702 | Off-center |

IMPORTANT

All 28" or 34" wide multi-purpose upright accessories are compatible with multi-purpose stands AS LONG AS all security recommendations are followed. For further information, contact your customer service representative.

SEE PAGES 146-150