

Arlink® 7000 Workbench Systems

Arlink 7000 Workbench Systems help companies like yours optimize performance in the workplace by providing efficient, ergonomic, and well-designed workbenches which significantly improve productivity, maximize use of floor space and produce a safer work environment.

SUPERIOR VERSATILITY

Arlink 7000 workbenches let you tailor your benches to your needs while providing greater versatility than competitive workbenches. Whether you select stationary or mobile, or choose from our extensive selection of accessories, you can design a workbench that exactly suits your requirements.

For drawer cabinet pedestal-based workbenches, see Lista's General Workbench and Workspace Solutions Catalog.



 **Custom Products & Services, Inc.**
PH: 888-444-1202
E-Mail: info@custom-products.com

Arlink® 7000 Workbench Features and Benefits

HEAVY-DUTY QUALITY

- Heavy-duty construction is capable of supporting 1,000 lbs. (454 kg), evenly distributed.
- Durable worksurface choices include plastic laminate, static dissipative laminate, butcher block, stainless steel, galvanized steel and Lista top. See page 5 for worksurface descriptions.

HEIGHT-ADJUSTABLE LEGS

- Stationary workbenches include leg extenders, which enable the user to adjust the height of the work-surface from 30" to 36" (76-91 cm) in 2" (5 cm) increments.

CLEAN ROOM COMPATIBILITY

- Workbenches may be configured for use in Class 10,000 clean rooms per the USA Federal Standard 209E and Class 7 per ISO 14644 International Clean Room Standard.

STATIC ELECTRICITY CONTROL

- Static dissipative laminate worksurfaces, ESD mat kits and other static-safe accessories make your workbenches the perfect component in any static-dissipative environment. For ESD accessories, see page 25.

VARIETY OF ACCESSORY CHOICES

- Numerous above- and below-worksurface accessories allow you to customize your Arlink 7000 workbench to exactly suit your needs.
- Unique VSI (Vertical Space Integrator) System enables use of all Arlink 8000 accessories, greatly enhancing the versatility and utility of your workbench. See page 34 for details.

MOBILITY

- Mobile workbenches and mobile companion cabinets are easily relocated, allowing fast layout changes and easy cleaning.

SECURE STORAGE

- Hanging drawers and/or companion cabinets can be added anywhere you need them to provide secure storage for valuable tools, equipment, parts or personal effects.

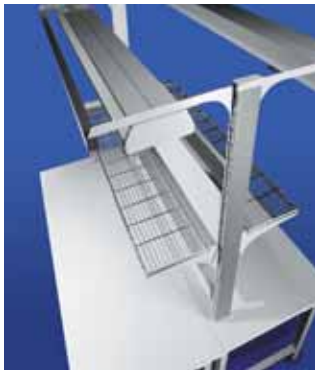

The VSI System (see page 34) allows use of all Arlink 8000 accessories on Arlink 7000 workbenches.



 **Custom Products & Services, Inc.**
PH: 888-444-1202
E-Mail: info@custom-products.com

Easy-Order Arlink® 7000 Workbenches

WORKBENCH STYLES

Arlink 7000 workbenches are available in two styles: stationary and mobile. Simply choose the base style that best suits your needs.

- Add appropriate accessories from pages 31-34
- For worksurface descriptions, see page 5
- For optional hanging drawers, see page 32
- For companion stationary or mobile drawer storage cabinets, see page 35
- For other dimensions, please contact your Lista representative

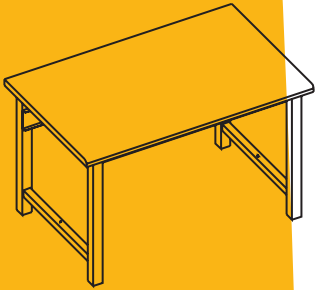

ARLINK 7000 STATIONARY WORKBENCH

Includes stationary workbench frame (for description, see page 31). Nominal bench height is 30" (76 cm).

To configure an Arlink 7000 stationary workbench

- Choose bench length desired:
 - 48" (122 cm)
 - 60" (152 cm)
 - 72" (183 cm)
 - 84" (213 cm)
 - 96" (244 cm)
- Choose bench depth desired:
 - 30" (76 cm)
 - 36" (91 cm)
- Add 30 to denote 30" bench height
- Choose worksurface desired:
 - SL (standard laminate)
 - SD (static dissipative)
 - BB (butcher block)
 - SS (stainless steel)
 - ST (galvanized steel)
 - LT (Lista top)
 - NT (no top required)
- Choose powder coat paint color:
 - LG (Light Gray)
 - SN (Sand)

Example: to order a stationary workbench that is 72" long and 30" deep with a standard laminate worksurface and a Light Gray finish, the part number would be **723030SLLG**.

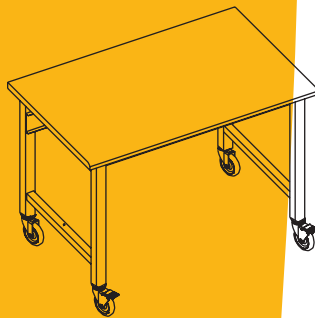

ARLINK 7000 MOBILE WORKBENCH

Includes mobile workbench frame (for description, see page 31). Nominal bench height is 36" (91 cm).

To configure an Arlink 7000 mobile workbench

- Choose bench length desired:
 - 48" (122 cm)
 - 60" (152 cm)
 - 72" (183 cm)
 - 84" (213 cm)
 - 96" (244 cm)
- Choose bench depth desired:
 - 30" (76 cm)
 - 36" (91 cm)
- Add 36 to denote 36" bench height
- Choose worksurface desired:
 - SL (standard laminate)
 - SD (static dissipative)
 - BB (butcher block)
 - SS (stainless steel)
 - ST (galvanized steel)
 - LT (Lista top)
 - NT (no top required)
- Add C to denote mobile/with casters
- Choose powder coat paint color:
 - LG (Light Gray)
 - SN (Sand)

Example: to order a mobile workbench that is 84" long and 30" deep with a static dissipative worksurface and a Sand finish, the part number would be **843036SDCSN**.

Arlink® 7000 Workbench Components

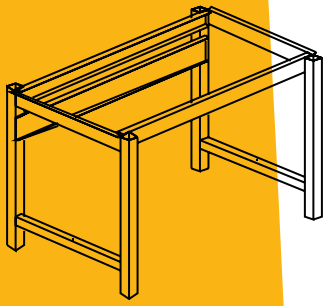

STATIONARY WORK-BENCH FRAME

Includes 2 leg assemblies, 2 load beams, 1 stiffener, 1 set of 6" leg extenders and hardware. By using the leg extenders, the workbench height is adjustable from 30" (76 cm) to 36" (91 cm) in 2" (5 cm) increments. Load capacity for all benches is 1,000 lbs. (454 kg) evenly distributed. Nominal bench height is 30" (76 cm).

Workbench Length	Depth 30" (76 cm)	36" (91 cm)
48" (122 cm)	483030NT	483630NT
60" (152 cm)	603030NT	603630NT
72" (183 cm)	723030NT	723630NT
84" (213 cm)	843030NT	843630NT
96" (244 cm)	963030NT	963630NT

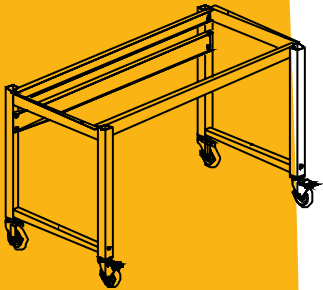

MOBILE WORKBENCH FRAME

Same construction as Arlink 7000 stationary workbench frame. Frame includes 2 mobile leg assemblies (with 4 swivel casters, 2 of which have wheel locks), 2 load beams, 1 stiffener and hardware. Nominal bench height is 36" (91 cm).

Workbench Length	Depth 30" (76 cm)	36" (91 cm)
48" (122 cm)	483030NTC	483630NTC
60" (152 cm)	603030NTC	603630NTC
72" (183 cm)	723030NTC	723630NTC
84" (213 cm)	843030NTC	843630NTC
96" (244 cm)	963030NTC	963630NTC



SKIRTING PANELS

Steel skirting panels enclose ends and back of bench.

Workbench D x H	Description	Part No.
30" x 30" (76 x 76 cm)	end panel	3030EM
36" x 30" (91 x 76 cm)	end panel	3630EM
48" x 30" (122 x 76 cm)	rear panel	4830RM
60" x 30" (152 x 76 cm)	rear panel	6030RM
72" x 30" (183 x 76 cm)	rear panel	7230RM
84" x 30" (213 x 76 cm)	rear panel	8430RM
96" x 30" (244 x 76 cm)	rear panel	9630RM

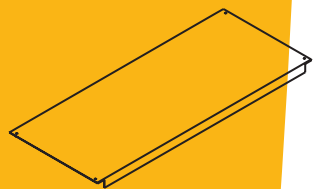

UNDER SHELF

For extra storage space under bench, this 18" (46 cm) deep lower steel shelf fastens to the leg braces. (A footrest is required with under shelf – see below.)

Workbench Length	Part No.
48" (122 cm)	7Z4818US
60" (152 cm)	7Z6018US
72" (183 cm)	7Z7218US
84" (213 cm)	7Z8418US
96" (244 cm)	7Z9618US



FIXED HEAVY GAUGE FOOTREST

Channel steel footrest mounts between horizontal leg tubes.

Workbench Length	Part No.
48" (122 cm)	7E48FR
60" (152 cm)	7E60FR
72" (183 cm)	7E72FR
84" (213 cm)	7E84FR
96" (244 cm)	7E96FR

PLEASE SPECIFY PAINT COLOR FOR ALL ORDERS – LIGHT GRAY (LG) OR SAND (SN)

Arlink® 7000 Below-Worksurface Options

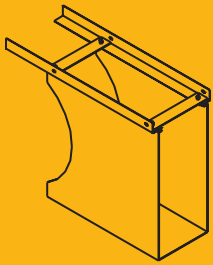

CPU HOLDER

Allows CPU to be mounted under worksurface (off of floor), with access to rear of CPU. Mounts under worksurface, and can slide to any horizontal position.

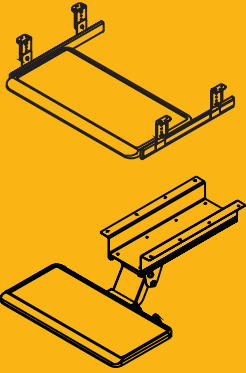

KEYBOARD HOLDER

Pullout keyboard holder allows computer keyboard to be stored under worksurface when not in use. Swivel holder pivots horizontally and vertically to provide maximum ergonomic comfort.

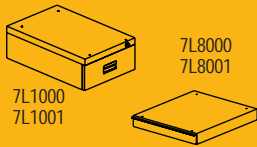

7L1000
7L1001

7L8000
7L8001

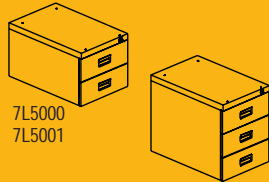

7L5000
7L5001

7L3000
7L3001



7L2000
7L2001

HANGING DRAWER ASSEMBLY

Steel drawer mounts under worksurface, and can slide to any horizontal position. Includes steel ball bearings, recessed handles and drawer stops. 100% full extension. Each drawer comes with a lock and each assembly comes with 2 keys. Includes mounting brackets.

W x D x H	Use with Worksurface	Part No.
9 1/2" x 22" x 19" (24 x 56 x 48 cm)	30" (76 cm) deep	7L7000
9 1/2" x 22" x 19" (24 x 56 x 48 cm)	36" (91 cm) deep	7L7001

Description	W x D	Part No.
pullout for keyboard only	21" x 10" (53 x 25 cm)	7Z1025
pullout for keyboard and mouse	28" x 10" (71 x 25 cm)	7Z1026
swivel for keyboard only	21" x 10" (53 x 25 cm)	7Z1010
swivel for keyboard and mouse	28" x 10" (71 x 25 cm)	7Z1011

Drawer(s)	Height	For Worksurface Depth	Part No.
1 drawer	6 1/4" (16 cm)	30" (76 cm)	7L1000
1 drawer	6 1/4" (16 cm)	36" (91 cm)	7L1001
1 drawer (shallow)*	3" (8 cm)	30" (76 cm)	7L8000
1 drawer (shallow)*	3" (8 cm)	36" (91 cm)	7L8001
2 drawer	13" (33 cm)	30" (76 cm)	7L5000
2 drawer	13" (33 cm)	36" (91 cm)	7L5001
2 drawer with file drawer	19 1/2" (50 cm)	30" (76 cm)	7L2000
2 drawer with file drawer	19 1/2" (50 cm)	36" (91 cm)	7L2001
3 drawer	19 1/2" (50 cm)	30" (76 cm)	7L3000
3 drawer	19 1/2" (50 cm)	36" (91 cm)	7L3001

*no lock available

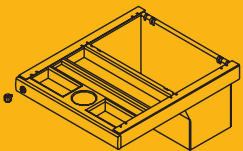

PELICAN® DRAWER

See description on page 19.

For Worksurface Depth	Part No.
30" (76 cm)	7L6000
36" (91 cm)	7L6001

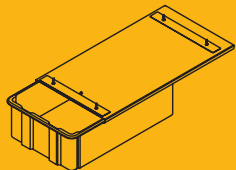

TOTE BOX ASSEMBLY

See description on page 19.

For Worksurface Depth	Part No.
30" (76 cm)	7L4000
36" (91 cm)	7L4001

For additional components:

- turbo trays, page 21
- freestanding footrest, page 21
- ESD accessories, page 25



PLEASE SPECIFY PAINT COLOR FOR ALL ORDERS – LIGHT GRAY (LG) OR SAND (SN)

Arlink® 7000 Above-Worksurface Options

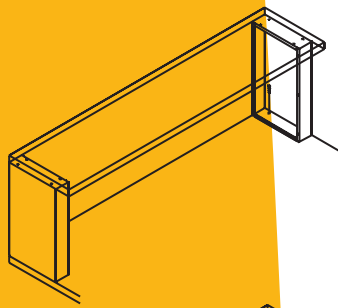

RISER SHELF WITH BOX SUPPORTS

14" (36 cm) deep shelves are finished in either standard or static dissipative laminate to match specified worksurface. Steel box supports are 19" (48 cm) high and 11" (28 cm) deep.

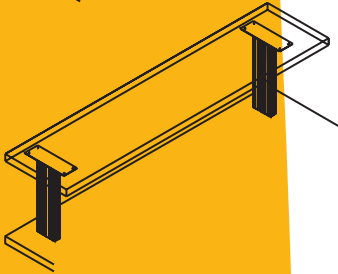

RISER SHELF COLUMN SUPPORT

Column supports are 15" (38 cm) high and mount on 36" (91 cm), 48" (122 cm), 60" (152 cm) and 72" (183 cm) centers. These sturdy columns have a dual slot system to accept Arlink 8000 accessories (see pages 14-24).



ELECTRICAL PANEL INSERT FOR BOX SUPPORT

The panel insert includes illuminated 15 amp circuit breaker, 4 duplex receptacles and power cord. Electrical panels can be used on one or both shelf supports and can be purchased with shelf or added later.

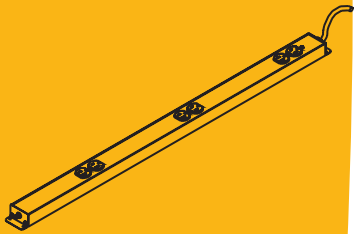

HORIZONTAL POWER BEAM

Includes number of outlets shown in chart and 7 1/2' power cord. Mounts in Micro slots.

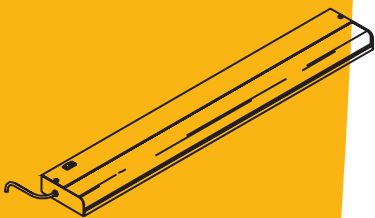

LIGHT FIXTURE FOR UNDER SHELF

Fastens to underside of riser shelf with wood screws. Includes acrylic diffuser, 7 1/2' power cord and rocker switch. Lights feature economical electronic ballasts and come complete with T8 fluorescent lamp.



BACK AND END STOPS

Steel stops fasten to worksurface to provide back and end stops. Stops extend approx. 4" above workbench top. End stops are 30" deep and have rounded front corners. Back stop can also be attached to riser shelf.

L x D x H	Standard Laminate*	Static Dissipative*
48" x 14" x 19" (122 x 36 x 48 cm)	481419SL	481419SD
60" x 14" x 19" (152 x 36 x 48 cm)	601419SL	601419SD
72" x 14" x 19" (183 x 36 x 48 cm)	721419SL	721419SD
84" x 14" x 19" (213 x 36 x 48 cm)	841419SL	841419SD
96" x 14" x 19" (244 x 36 x 48 cm)	961419SL	961419SD

*other materials available upon request

L x D x H	Standard Laminate*	Static Dissipative*
48" x 14" x 15" (122 x 36 x 38 cm)	481415CSL	481415CSD
60" x 14" x 15" (152 x 36 x 38 cm)	601415CSL	601415CSD
72" x 14" x 15" (183 x 36 x 38 cm)	721415CSL	721415CSD
84" x 14" x 15" (213 x 36 x 38 cm)	841415CSL	841415CSD

*other materials available upon request

Part No.

7Z19EP

Description

Part No.

36" (91 cm) for 48" (122 cm) bench, 6 outlets	7H48PB
48" (122 cm) for 60" (152 cm) bench, 8 outlets	7H60PB
60" (152 cm) for 72" (183 cm) bench, 10 outlets	7H72PB
72" (183 cm) for 84" (213 cm) bench, 12 outlets	7H84PB
84" (213 cm) for 96" (244 cm) bench, 14 outlets	7H96PB

Length

Part No.

36" (91 cm)	7Z36USL
48" (122 cm)	7Z48USL

L x H

Back Stop Only

Back and End Stops

48" x 4" (122 x 10 cm)	7J48BS	48BES
60" x 4" (152 x 10 cm)	7J60BS	60BES
72" x 4" (183 x 10 cm)	7J72BS	72BES
84" x 4" (213 x 10 cm)	7J84BS	84BES
96" x 4" (244 x 10 cm)	7J96BS	96BES

For the VSI Accessory System, see page 34.

PLEASE SPECIFY PAINT COLOR FOR ALL ORDERS - LIGHT GRAY (LG) OR SAND (SN)

VSI (Vertical Space Integrator) System



TURN ANY WORKBENCH INTO A HIGH EFFICIENCY WORK CENTER

The VSI (Vertical Space Integrator) System is designed to expand the efficiency of Arlink® 7000 workbenches, as well as retrofitting to existing workbenches. You can create highly productive and efficient work centers by adding above-worksurface work aids such as task lighting, storage shelves, power beams, parts bin rails, etc.

With the VSI System, you're able to utilize the Arlink 8000 system's wide range of shelving and accessory options that easily attach to the vertical column without the need for tools.

The VSI System is available in 30" (76 cm), 36" (91 cm), 48" (122 cm), 60" (152 cm) and 72" (183 cm) wide modules, with a column height of 45" (114 cm). It is easily installed by in-house personnel and can be utilized as a single unit on a stand-alone bench, or linked together using our Starter/Adder system. VSI columns are double-sided, and one VSI may service two benches when benches are positioned back-to-back (see photo below).

Conversion and retrofit of existing workbenches is fast and easy. Uprights mount onto the surface of almost any existing workbench with the hardware kit provided.

To order, select an assembly from the charts below. VSI System width must be a minimum of 6" shorter than worksurface width. The VSI system has Micro and Macro dual slot mechanism on both sides of the upright columns (see page 8 for detailed descriptions).

VSI uprights and accessories mount onto any workbench worksurface to provide a complete accessory system. Mounted on a bench with a second bench positioned behind it (far right), the uprights and accessories can be shared between the two benches thanks to the VSI uprights' double-sided columns.



VSI (VERTICAL SPACE INTEGRATOR) SYSTEM

Features sturdy 45" (114 cm) high, roll-formed steel columns that fasten to the bench top and are stabilized by a modesty panel.

Starter assembly includes 2 columns, 4 trim strips, 1 modesty panel, and mounting hardware. Adder assembly includes 1 mounting column, 2 trim strips, 1 modesty panel and mounting hardware.

Trim strip color can be chosen from the chart on page 4.

For VSI system accessories, see pages 14-25.

COLUMN CAP

Optional gray plastic cap to finish off top of column. Order 1 per column used.

Module Width*	VSI Starter Assembly	VSI Adder Assembly
30" (76 cm)	8352	8353
36" (91 cm)	8826	8828
48" (122 cm)	8855	8856
60" (152 cm)	8672	8673
72" (183 cm)	8793	-

*must be a minimum of 6" shorter than worksurface width

W x D	Part No.
1 1/2" x 4" (4 x 10 cm)	8004



Custom Products & Services, Inc.

PH: 888-444-1202

E-Mail: info@custom-products.com

PLEASE SPECIFY PAINT COLOR FOR ALL ORDERS – LIGHT GRAY (LG) OR SAND (SN)

Lista Narrow Width (NW) Stationary and Mobile Companion Cabinets



Lista NW companion cabinets allow the storage of frequently-used tools, parts and files adjacent to your work area. These cabinets are ideal for the most demanding storage needs while providing easy access to the drawer interior. Companion cabinets are the perfect complement to an Arlink® 7000 workbench or Arlink® 8000 workstation, providing additional drawer storage. Mobile companion cabinets allow stored items to be shared among workstations.

- Select from 6 standard cabinet configurations in 4 different heights, or order your cabinet with a mobile base for additional flexibility. Our space-efficient cabinets all measure 16 7/8" (43 cm) wide x 28 1/2" (72 cm) deep. Mobile cabinets are mounted on 3 1/2" (9 cm) diameter casters (2 fixed, 2 swivel) with wheel locks, and include individual drawer latches on all drawers.
- Cabinets feature full height sidewalls and steel roller bearings. Drawers can be rearranged within the cabinet in any order you choose. Optional drawer partitions and dividers (see below) let you customize each drawer interior for additional organization of drawer contents.
- All cabinets come with a lock and 2 keys.
- Drawers have 150 lb. (68 kg) capacity and 95% extension. 11" (28 cm) high drawers store hanging letter files.

To order a cabinet, add your choice of powder coat paint color in place of the box: **LG** (Light Gray) or **SN** (Sand)

1-DRAWER, 1 SHELF W/ REVERSIBLE DOOR CABINET

Base	Height	Part No.
none	27 1/2" (70 cm)	NW0600-0202N-NBRG
2"	29 1/2" (75 cm)	NW0600-0202N-2RG
4"	31 1/2" (80 cm)	NW0600-0202N-4RG
6"	33 1/2" (85 cm)	NW0600-0202N-6RG
mobile	32 1/2" (83 cm)	NW0600-0202N-M-RG

2-DRAWER CABINET

Base	Height	Part No.
none	27 1/2" (70 cm)	NW0600-0201N-NBRG
2"	29 1/2" (75 cm)	NW0600-0201N-2RG
4"	31 1/2" (80 cm)	NW0600-0201N-4RG
6"	33 1/2" (85 cm)	NW0600-0201N-6RG
mobile	32 1/2" (83 cm)	NW0600-0201N-M-RG

3-DRAWER CABINET

Base	Height	Part No.
none	27 1/2" (70 cm)	NW0600-0301N-NBRG
2"	29 1/2" (75 cm)	NW0600-0301N-2RG
4"	31 1/2" (80 cm)	NW0600-0301N-4RG
6"	33 1/2" (85 cm)	NW0600-0301N-6RG
mobile	32 1/2" (83 cm)	NW0600-0301N-M-RG

4-DRAWER CABINET

Base	Height	Part No.
none	27 1/2" (70 cm)	NW0600-0402N-NBRG
2"	29 1/2" (75 cm)	NW0600-0402N-2RG
4"	31 1/2" (80 cm)	NW0600-0402N-4RG
6"	33 1/2" (85 cm)	NW0600-0402N-6RG
mobile	32 1/2" (83 cm)	NW0600-0402N-M-RG

4-DRAWER CABINET

Base	Height	Part No.
none	27 1/2" (70 cm)	NW0600-0404N-NBRG
2"	29 1/2" (75 cm)	NW0600-0404N-2RG
4"	31 1/2" (80 cm)	NW0600-0404N-4RG
6"	33 1/2" (85 cm)	NW0600-0404N-6RG
mobile	32 1/2" (83 cm)	NW0600-0404N-M-RG

5-DRAWER CABINET

Base	Height	Part No.
none	27 1/2" (70 cm)	NW0600-0501N-NBRG
2"	29 1/2" (75 cm)	NW0600-0501N-2RG
4"	31 1/2" (80 cm)	NW0600-0501N-4RG
6"	33 1/2" (85 cm)	NW0600-0501N-6RG
mobile	32 1/2" (83 cm)	NW0600-0501N-M-RG

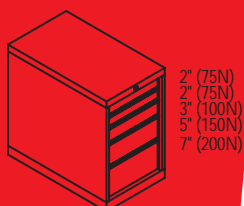
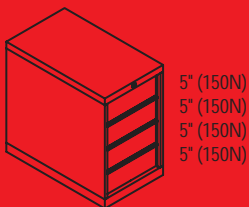
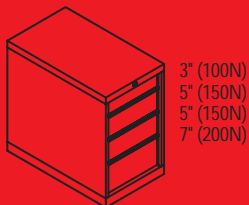
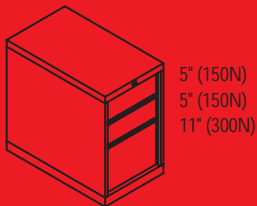
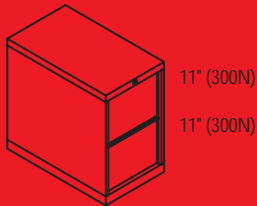
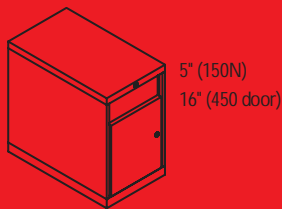

DRAWER INTERIORS

Pre-configured drawer interior sets may be ordered for the drawer heights indicated in the charts below.

- NWDR012 interiors include high-impact red polystyrene plastic boxes, suitable for storing a variety of small parts. Boxes are easily removed from drawer for easy loading and dispensing.
- NWDR209 and NWDR106 interiors include slotted steel vertical partitions with aluminum drawer dividers for creating the exact-sized compartments your work requires.



NWDR012 INTERIOR

- includes (8) 3" x 6" boxes
- includes (4) 6" x 6" boxes

For Drawer Ht.	Part No.
2"	NWDR012-3
3"	NWDR012-4



NWDR209 INTERIOR

- creates (6) 3 1/2" wide compartments
- creates (3) 4 1/8" wide compartments

For Drawer Ht.	Part No.
2"	NWDR209-3
3"	NWDR209-4
5"	NWDR209-6



NWDR106 INTERIOR

- creates (3) 5 1/2" wide compartments
- creates (3) 6 1/4" wide compartments

For Drawer Ht.	Part No.
2"	NWDR106-3
3"	NWDR106-4
5"	NWDR106-6
7"	NWDR106-8

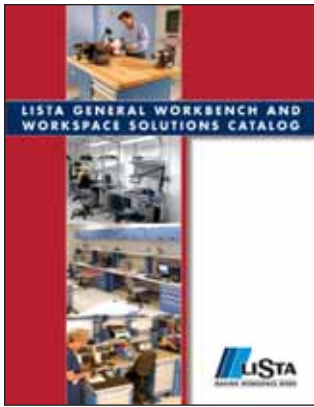

For information about Lista's comprehensive line of workbenches, height-adjustable workstations, accessory systems, flow racks, trolleys and other workspace solutions, ask for our General Workbench and Workspace Solutions Catalog.



Lista International Corporation
 106 Lowland Street
 Holliston, MA 01746-2094 USA
 Phone: (800) 722-3020
 Fax: (508) 626-0353
 Internet: www.listaintl.com
 E-mail: sales@listaintl.com

ISO 9001 Certified



Lista Technical Electronic Workbenches

Featuring a sleek, aesthetically attractive design, the real beauty of Lista's technical electronic workbenches is their ability to perfectly suit the widest variety of applications. Lista's modular approach is the key to our technical benches' versatility, with flexible standard components and accessory options both above and below the work-surface.



Align™ Adjustable Height Workstations

The Align adjustable height workstation features 16" of travel between 25 1/2" and 41 1/2". Users can adjust the bench height with the simple turn of a crank, motor drive or via slide leg. Load capacity is 1,000 lbs. evenly distributed. Features advanced ergonomic design. Also available in mobile configuration.



Lista Industrial Workbenches

Rugged, durable, built to handle the harshest work environments. Lista's industrial workbenches feature flexible standard components and can be cost-effectively custom configured to meet the specific needs of your application.



Lista Packing and Shipping Workbenches

Lista's advanced, modular workbenches are specifically designed for packing and shipping applications. These flexible benches bundle together an array of superior features and accessories to suit almost any need.



Product specifications are subject to change without notice and are those in effect at time of order receipt.

© 2006 Lista International Corporation
 Printed in U.S.A. 3-06 20M