

CALL TO ORDER: 888-444-1202

“EVOLUTION” TECH BENCH SPECIFIER

The “**EVOLUTION**” series assembly bench is the new look in modular workstations. The information contained here will provide you with step-by-step instructions that will allow you to order the workstation the meets all of your requirements.



The **EVOLUTION** series workstations are a totally “modular” system designed to conform to your specific requirements. Whether you need single or double sided, standard or ESD, sit-down or stand-up height, standard or special power distribution, this system can accommodate your requirements.

Contact CPS if you have any questions or if you need assistance in designing the workstation.

CALL TO ORDER: 888-444-1202

“EVOLUTION” TECH BENCH

PRODUCT VOCABULARY

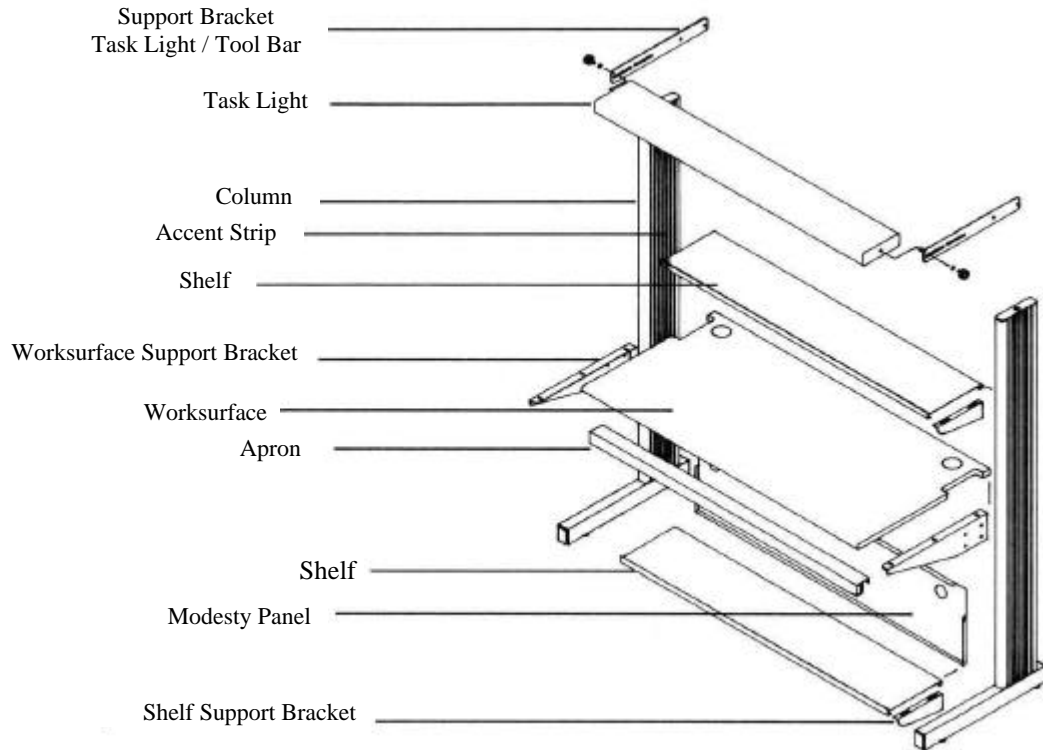

“EVOLUTION” SPECIFIER—HOW TO ORDER

We recommend the specifications of the room layout be determined in advance of ordering the actual workstations. The end result is a well planned production area that meets your requirements, saves money and provides your personnel with an ergonomically designed productive work area.

TO BEGIN:

- 1) Measure the allocated space.
- 2) Determine personnel requirements.
- 3) Specify features important for operational requirements.

ORDERING A WORKSTATION:

- 1) Select: Low Column Workstation
 Mid Column Workstation
 High Column Workstation
 Double-Sided Workstation

- 2) Determine the width of the workstation: 48”, 60” or 72”.

Workstation width is measured from centerline of column to centerline of column.

- 3) Specify the color of the worksurface and accent strips for the workstation

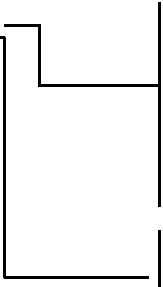
Example: Product #407304		<p>A = Almond Accent</p> <p>K = Black Accent</p> <p>W = Wineberry Accent</p> <p>B = Blue Accent</p> <p>G = Gray Accent</p> <hr style="width: 100%;"/> <p>A = Almond Worksurface</p> <p>G = Gray Worksurface</p>
--------------------------	---	--

- 4) Specify the painted steel color: Sand Tan, Gray, white or Black
Customized paint colors can be specified to meet your needs.

- 5) ESD workstations and bridge units are shown with standard workstations.

ESD worksurface / accent strip colors are:

- AA** = Almond worksurface with almond accent
- GG** = Gray worksurface with gray accent

- 6) Select workstation accessories (Lighting, shelving, corner units, electrical, storage, etc.)

EVOLUTION—SPECIFIER

LOW COLUMN WORKSTATIONS

Basic Workstations include a front radius edge worksurface, (2) supporting columns with bases and glides. Worksurface support brackets, apron and modesty panel are also included.

Add-on Workstations include all items listed above except (1) supporting column and base. Add-on Workstation shares the column and base from an existing adjacent Basic Workstation.

ESD Workstations are supplied with all grounding hardware and static dissipative laminate.

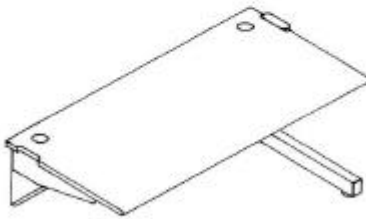
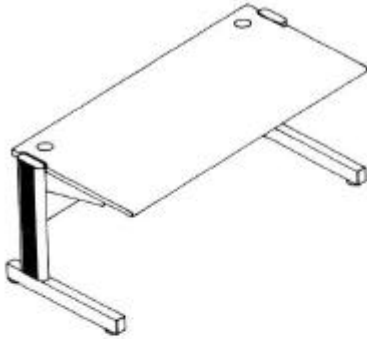

BASIC WORKSTATION

MAX. HT	DEPTH	WIDTH	PART # STANDARD	PART # ESD	WT.
30"	30"	48"	407304__	407354__	123
		60"	407305__	407355__	138
		72"	407306__	407356__	153

ADD-ON WORKSTATION

MAX. HT	DEPTH	WIDTH	PART # STANDARD *	PART # ESD *	WT.
30"	30"	48"	407307__	407357__	104
		60"	407308__	407358__	119
		72"	407309__	407359__	134

Specify color preference with a suffix to the product number:
 For Example, product number 407304__
 Requires a worksurface color code **first**, accent color code **second**.

Worsurface colors: **A** = Almond **G** = Gray

Accent colors: **A** = Almond, **K** = Black, **W** = Wineberry
B = Blue, **G** = gray

ESD Worksurface / Accent colors: **AA** = Almond **GG** = Gray

EVOLUTION—SPECIFIER

MID COLUMN WORKSTATIONS

Basic Workstations include a front radius edge worksurface, (2) supporting columns with bases and glides. Worksurface support brackets, apron and modesty panel are also included.

Add-on Workstations include all items listed above except (1) supporting column and base. Add-on Workstation shares the column and base from an existing adjacent Basic Workstation.

ESD Workstations are supplied with all grounding hardware and static dissipative laminate.

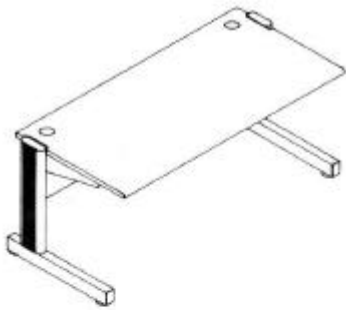

BASIC WORKSTATION

MAX. HT	DEPTH	WIDTH	PART # STANDARD	PART # ESD	WT.
36"	30"	48"	407314__	407364__	125
		60"	407315__	407365__	142
		72"	407316__	407366__	157



ADD-ON WORKSTATION

MAX. HT	DEPTH	WIDTH	PART # STANDARD *	PART # ESD *	WT.
36"	30"	48"	407317__	407367__	106
		60"	407318__	407368__	121
		72"	407319__	407369__	136

Specify color preference with a suffix to the product number:
 For Example, product number 407304__
 Requires a worksurface color code **first**, accent color code **second**.

Worsurface colors: **A** = Almond **G** = Gray
Accent colors: **A** = Almond, **K** = Black, **W** = Wineberry
B = Blue, **G** = gray

ESD Worksurface / Accent colors: **AA** = Almond **GG** = Gray

EVOLUTION—SPECIFIER

HIGH COLUMN WORKSTATIONS

Basic Workstations include a front radius edge worksurface, (2) supporting columns with bases and glides. Worksurface support brackets, apron and modesty panel are also included.

Add-on Workstations include all items listed above except (1) supporting column and base. Add-on Workstation shares the column and base from an existing adjacent Basic Workstation.

ESD Workstations are supplied with all grounding hardware and static dissipative laminate.

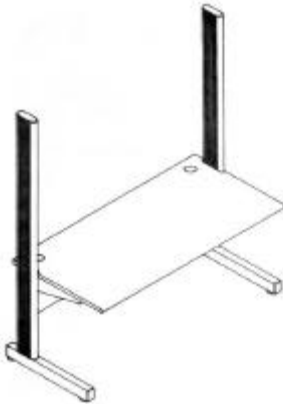

BASIC WORKSTATION

MAX. HT	DEPTH	WIDTH	PART # STANDARD	PART # ESD	WT.
76"	30"	48"	407324__	407374__	153
		60"	407325__	407375__	168
		72"	407326__	407376__	183

ADD-ON WORKSTATION

MAX. HT	DEPTH	WIDTH	PART # STANDARD *	PART # ESD *	WT.
76"	30"	48"	407327__	407377__	119
		60"	407328__	407378__	135
		72"	407329__	407379__	149



Specify color preference with a suffix to the product number:

For Example, product number 407304__

Requires a worksurface color code **first**, accent color code **second**.

Worsurface colors: **A** = Almond **G** = Gray

Accent colors: **A** = Almond, **K** = Black, **W** = Wineberry

B = Blue, **G** = gray

ESD Worksurface / Accent colors: **AA** = Almond **GG** = Gray

EVOLUTION—SPECIFIER

DOUBLE SIDED WORKSTATIONS

Basic Workstations include (2) front radius edge worksurface that share (2) supporting columns with bases and glides. Worksurface support brackets, (2) aprons and (2) modesty panels are also included.

Add-on Workstations include all items listed above except (1) supporting column and base. Add-on Workstation shares the column and base from an existing adjacent Basic Workstation.

ESD Workstations are supplied with all grounding hardware and static dissipative laminate.

BASIC WORKSTATION



MAX. HT	DEPTH	WIDTH	PART # STANDARD	PART # ESD	WT.
76"	30"	48"	407334__	407384__	249
		60"	407335__	407385__	279
		72"	407336__	407386__	309

ADD-ON WORKSTATION



MAX. HT	DEPTH	WIDTH	PART # STANDARD *	PART # ESD *	WT.
76"	30"	48"	407337__	407387__	206
		60"	407338__	407388__	236
		72"	407339__	407389__	266

Specify color preference with a suffix to the product number:
 For Example, product number 407304__
 Requires a worksurface color code **first**, accent color code **second**.

Worsurface colors: **A** = Almond **G** = Gray
Accent colors: **A** = Almond, **K** = Black, **W** = Wineberry
B = Blue, **G** = gray

ESD Worksurface / Accent colors: **AA** = Almond **GG** = Gray

EVOLUTION—SPECIFIER

CORNER UNITS

Corner units are used to connect workstations into an “L” or “U” shape configuration. They must be used in conjunction with (2) free-standing workstations. Corner units include a front radius edge worksurface and support brackets.

ESD corner units are supplied with all grounding hardware and static dissipative laminate.

RADIUS CORNERS



DESCRIPTION	STANDARD LAMINATE *	ESD LAMINATE *	WT.
90° Worksurface Single to single	407030_	407030_E	40

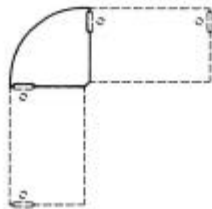

DESCRIPTION	STANDARD LAMINATE *	ESD LAMINATE *	WT.
90° Worksurface Single to double Right	407031_	407031_E	43

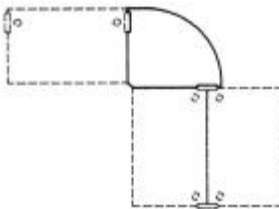

DESCRIPTION	STANDARD LAMINATE *	ESD LAMINATE *	WT.
90° Worksurface Single to double left	407032_	407032_E	43

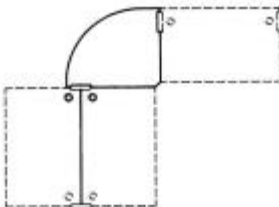

Specify color preference with a suffix to the product number:

Worksurface Colors: **A** = Almond or **G** = Gray

EVOLUTION—SPECIFIER

SQUARE CORNERS

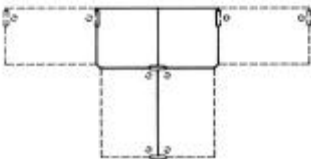
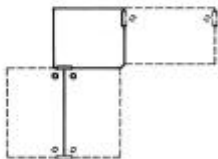
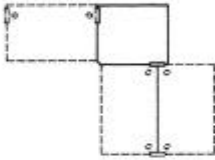

DESCRIPTION	STANDARD LAMINATE *	ESD LAMINATE *	WT.
Square Worksurface Single to single	407033_	407033_E	47

DESCRIPTION	STANDARD LAMINATE *	ESD LAMINATE *	WT.
Square Worksurface Single to double Right	407034_	407034_E	47

DESCRIPTION	STANDARD LAMINATE *	ESD LAMINATE *	WT.
Square Worksurface Single to double left	407035_	407035_E	47

DESCRIPTION	STANDARD LAMINATE *	ESD LAMINATE *	WT.
Linkage Element	407036_	407036_E	94

Specify color preference with a suffix to the product number:

Worksurface Colors: **A** = Almond or **G** = Gray

EVOLUTION—SPECIFIER

BRIDGE UNITS

Bridge units are used to convert empty space between workstations into usable work space. They must be used in conjunction with (2) free-standing workstations. The Basic Bridge includes a front radius edge worksurface, support brackets, apron and modesty panel.

The double-sided Bridge unit includes (2) front radius edge worksurfaces, (2) double-sided worksurface support brackets, (2) aprons and (2) modesty panels.

ESD Bridge units are supplied with all grounding hardware and static dissipative laminate.

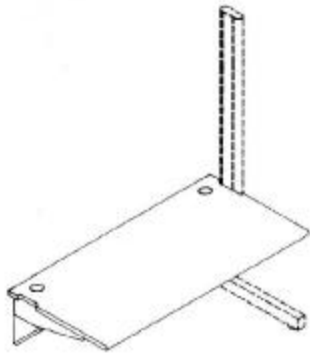

BASIC BRIDGE

DEPTH	WIDTH	STANDARD LAMINATE *	ESD LAMINATE *	WT.
30"	48"	407021_	407021_E	84
	60"	407022_	407022_E	99
	72"	407023_	407023_E	114

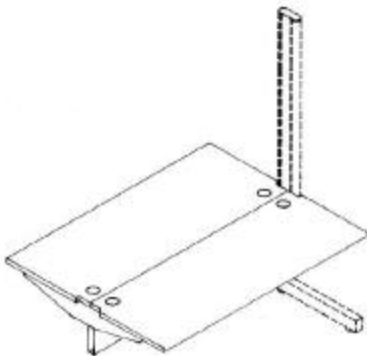

DOUBLE-SIDED BRIDGE

DEPTH	WIDTH	STANDARD LAMINATE *	ESD LAMINATE *	WT.
30"	48"	407026_	407026_E	164
	60"	407027_	407027_E	194
	72"	407028_	407028_E	224

Specify color preference with a suffix to the product number:

Worksurface Colors: **A** = Almond or **G** = Gray

EVOLUTION—SPECIFIER

SYSTEM SHELVING

Metal Shelves are offered with or without safety lip which runs the length of one side of the 12” deep shelf and both sides of the 18” deep shelf. The lip can be used for clip-on bins and various accessories.

All shelves may be mounted above or below the worksurface in a single or double-sided configuration. 12” deep shelves may be mounted at the same level and slanted in a double-sided configuration. 18” deep shelves must be mounted at different levels in a double-sided configuration. Support brackets allow up/down adjustment along the column as well as tilt capabilities.

ESD shelf mats are available. Refer to ESD Options section.

12” deep shelf

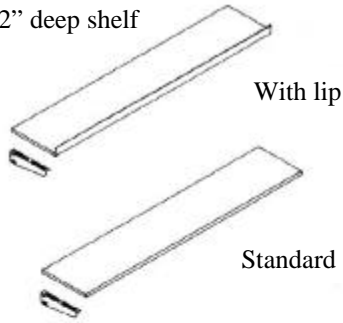

DEPTH	WORKSTATION WIDTH	WITHOUT LIP	WITH LIP (S)	WT.
12”	48”	407041	407051	23
	60”	407042	407052	35
	72”	407043	407053	27

18” deep shelf

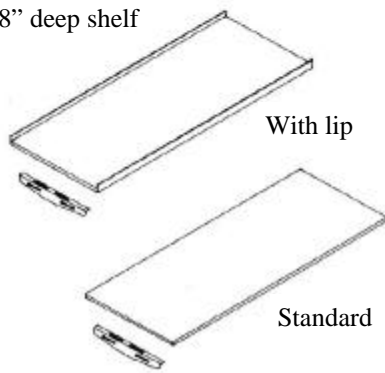

DEPTH	WORKSTATION WIDTH	WITHOUT LIP	WITH LIP (S)	WT.
18”	48”	407046	407056	29
	60”	407047	407057	31
	72”	407048	407058	33

EVOLUTION—SPECIFIER

SYSTEM STORAGE

All stackable or under-worksurface mounted drawers and cabinets are made of steel and feature metal drawer fronts with recessed handle or bow pulls. Personal and Box drawers are suspended with two-member ball bearing slides, and the file drawers are suspended with three-member ball bearing slides. Threaded inserts are supplied in all worksurfaces for easy installation to either end of the workstation.

Include (1) Mounting Bracket for each drawer configuration attaching directly to worksurface

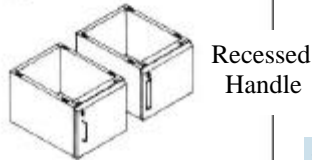
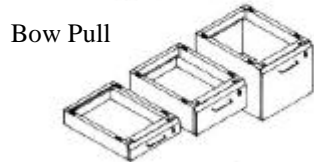
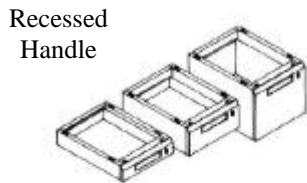

Bow Pull

Single box drawer and Swing Door combination



Single box drawer and File Drawer combination

GENERAL DIMENSIONS

DESCRIPTION	DEPTH	WIDTH	HEIGHT
Personal Drawer	18"	12-1/8"	1-1/2"
Box Drawer	18"	12-1/8"	4-1/2"
File Drawer	18"	12-1/8"	9-1/2"
Left Door Cabinet	19-1/2"	13"	11-3/4"
Right Door Cabinet	19-1/2"	13"	11-3/4"

LOCKABLE HANGING DRAWERS / CABINETS

DESCRIPTION	OVERALL HT	RECESSED HANDLE	BOW HANDLE	WT.
Personal Drawer	4"	407400	407401	8
Box Drawer	7"	407402	407403	16
File Drawer	14"	407404	407405	32
Left Door Cabinet	14"	407406	407407	19
Right Door Cabinet	14"	407408	407409	19

DESCRIPTION	PART #	WT.
Mounting Bracket	407420	6

Note: Please specify keying and color instructions when ordering. Drawers can be keyed alike, differently, by workstation or by area. Drawer / cabinet front colors: Sand, Tan, Gray, White or Black

EVOLUTION—SPECIFIER

OVERHEAD STORAGE

Overhead Storage units are made of steel and include a locking, internal retracting door and all necessary mounting hardware. Outside dimensions are 15" (H) x 15" (D), with actual widths of 46", 58" and 70". (All dimensions are nominal)

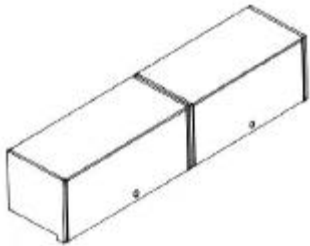

WORKSTATION WIDTH	DEPTH	PART #	WT.
48"	15"	407501	55
60"	15"	407502	68
72"	15"	407503	83

EVOLUTION—SPECIFIER

SYSTEM ELECTRICAL

Powered Backsplashes include 15 or 20 AMP grounded receptacles and an on/off switch with built-in circuit breaker. ESD Backsplashes feature dielectric insulation. Installation guide and mounting hardware included.

Order (1) 10 ft. power cord for each powered backplash unless a task light will be used along with backplash. In that case, (1) column electrical harness will connect and power both.

STANDARD BACKSPLASH

WORKSTATION WIDTH	OUTLETS	15 AMP	20 AMP	WT
48"	8	407131	407141	7
60"	8	407132	407142	10
72"	8	407133	407143	13

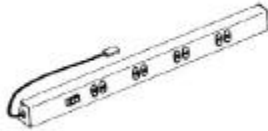

ESD BACKSPLASH

WORKSTATION WIDTH	OUTLETS	15 AMP	20 AMP	WT
48"	8	407131E	407141E	7
60"	8	407132E	407142E	10
72"	8	407133E	407143E	13

DESCRIPTION	15 AMP	20 AMP	WT
10 FT. Power Cord	407235	407236	1

DESCRIPTION	15 AMP	20 AMP	WT
Column Electrical Harness	407220	407230	1

EVOLUTION—SPECIFIER

UTILITY MANAGEMENT RACEWAY

All Utility Management Raceway components are manufactured of extruded aluminum alloy and anodized for durability. Basic components include raceway body and face plate covers. The covers snap on and off to allow complete flexibility and field modification. Select raceway body width and appropriate electric / utility fittings.

Cover options selected must add up to the total width of raceway. End caps are required at the beginning and end of a raceway run.

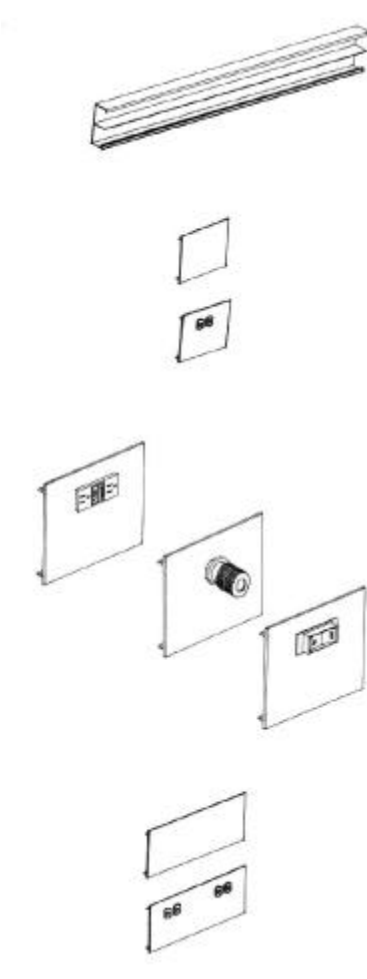

SURFACE MOUNT RACEWAY BODY

WORKSTATION WIDTH	DESCRIPTION	PART #	WT
48"	Surface Mount Raceway	407151	8
60"	Surface Mount Raceway	407152	10
72"	Surface Mount Raceway	407153	12

6" COVERS

WIDTH	DESCRIPTION	PART #	WT
6"	Blank Cover	ACCR0600	1
6"	1 duplex—15 AMP	ACCR0615	3
6"	1 duplex—20 AMP	ACCR0620	3
6"	Ground Fault Interrupter	ACCR06GF	3
6"	Quick Air Disconnect	ACC06QD	6
6"	Circuit Breaker	ACC06CB	2

12" COVERS

WIDTH	DESCRIPTION	PART #	WT
12"	Blank Cover	ACCR1200	2
12"	2 duplexes—15 AMP	ACCR1215	6
12"	2 duplexes—20 AMP	ACCR1220	6

EVOLUTION—SPECIFIER

UTILITY RACEWAY MANAGEMENT—PAGE 2

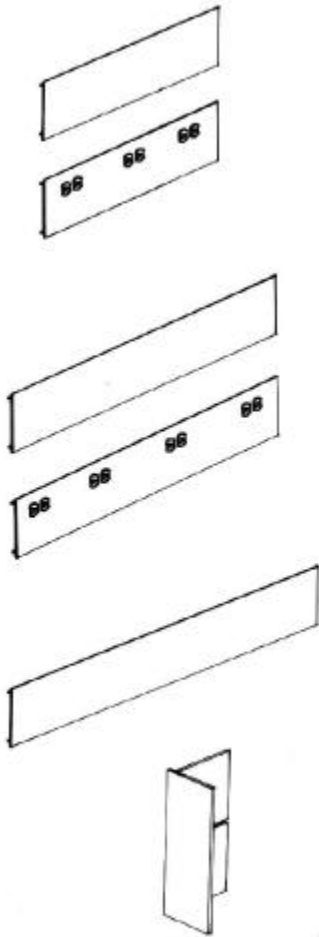

18' COVERS

WIDTH	DESCRIPTION	PART #	WT
18"	Blank Cover	ACCR1800	3
18"	3 duplexes—15 AMP	ACCR1815	9
18"	3 duplexes—20 AMP	ACCR1820	9

18' COVERS

WIDTH	DESCRIPTION	PART #	WT
24"	Blank Cover	ACCR2400	4
24"	4 duplexes—15 AMP	ACCR2415	12
24"	4 duplexes—20 AMP	ACCR2420	12

36' COVERS

WIDTH	DESCRIPTION	PART #	WT
36"	Blank Cover	ACCR3600	6

END CAPS

DESCRIPTION	PART #	WT.
1 End Cap	ACC000EC	1

FACTORY WIRING SERVICE

DESCRIPTION	PART #	WT.
Wiring Service—15 AMP	ACCWR15	3
Wiring Service—20 AMP	ACCWR20	3

NOTE: Please provide cover configuration when ordering wiring service

EVOLUTION—SPECIFIER

SYSTEM LIGHTING

Task Lights mount in-between two columns and include an energy saving ballast and on / off switch. Hand knob allows in/out and tilt adjustment on the light fixture bracket. Diffuser offers easy removal for fluorescent tube replacement.

(1) set of supports and (1) column electrical harness must be ordered separately for each task light.



TASK LIGHT

WORKSTATION WIDTH	PART #	WT.
48"	407101	24
60"	407102	26
72"	407103	28



LIGHT / TOOL BAR SUPPORT

DESCRIPTION	PART #	WT.
Single-sided Supports—Set of 2	407095	3
Double-sided Supports—Set of 2	407096	5

COLUMN ELECTRICAL HARNESS

DESCRIPTION	15 AMP	20 AMP	WT.
Column Electrical Harness	407220	407230	1

MAGINIFIER LIGHT



Reference CD index under "Lighting" for more options.

Magnifier Lights feature a 5", 3-diopter double convex precision ground lens which produces distortion-free magnification under bright fluorescent illumination. A 42" reach, steel arm with three-way adjustment is included. 6 ft. power cord included.

Include (1) Magnifier Light Bracket for each magnifier light.

DESCRIPTION	PART #	WT.
Magnifier Light	980030	9
Magnifier Light Bracket	407640	2

EVOLUTION—SPECIFIER

MOBILE CARTS

Carts include (4) 3" swivel casters with (2) of them locking. Cart shelves are laminated with rounded corners. Top shelf may be adjusted vertically along column.



LOW COLUMN CARTS

HEIGHT	DEPTH	WIDTH	STANDARD *	ESD *	WT
30"	18"	24"	407160__	407165__	74
30"	24"	36"	407161__	407166__	92

MID-COLUMN CARTS

HEIGHT	DEPTH	WIDTH	STANDARD *	ESD *	WT
36"	18"	24"	407162__	407167__	93
36"	24"	36"	407163__	407168__	111

*Specify color preference with a suffix to the product number:

For example, product #407304__

Requires a worksurface color **first**, and the accent code **second**.

Worksurface colors: **A** = Almond or **G** = Gray

Accent Colors: **A** = Almond, **BK** = Black, **W** = Wineberry

B = Blue, **G** = Gray

TOTE CARTS

HEIGHT	DEPTH	WIDTH	*PART #	WT
60"	18"	28"	407175	164

BIN CARTS

HEIGHT	DEPTH	WIDTH	*PART #	WT
60"	18"	38"	407176	113

*Specify color preference with a suffix to the product number:

Accent colors: **A** = Almond, **BK** = Black, **W** = Wineberry,

B = Blue or **G** = Gray

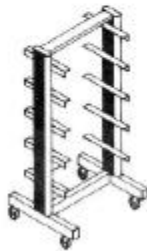

EVOLUTION—SPECIFIER

MOBILE PEDESTALS

Mobile Pedestals are made of steel and include a built-in cylinder lock. The pedestals are counterbalanced to protect against tilting and feature casters with a friction bracke to prevent inadvertent movement. A top is included with a built-in grip for ease of movement. Inside dimensions are: Personal Drawer 1-5/8" (H) , Box Drawer 4-1/2"(H), File Drawer 9-1/2" (H) and Door 11-5/8" (H). Pedestals are 24" (D) and available in 26" or 29" heights. All dimensions are nominal.



DRAWER / DOOR CONFIGURATION	HEIGHT	RECESSED HANDLE	BOW PULL	WT.
3 Box	26"	407430	407460	90

DRAWER / DOOR CONFIGURATION	HEIGHT	RECESSED HANDLE	BOW PULL	WT.
1 Box, 1 File	26"	407431	407461	85

DRAWER / DOOR CONFIGURATION	HEIGHT	RECESSED HANDLE	BOW PULL	WT.
1 Personal, 1 File	26"	407432	407462	90

DRAWER / DOOR CONFIGURATION	HEIGHT	RECESSED HANDLE	BOW PULL	WT.
1 Personal, 1 Box, 1 File	29"	407440	407470	98

DRAWER / DOOR CONFIGURATION	HEIGHT	RECESSED HANDLE	BOW PULL	WT.
1 Personal, 1 Door	29"	407441	407471	88

NOTE: Please specify keying and color instructions when ordering. Pedestals may be keyed alike, differently, by workstation or by area. Drawer / Cabinet front colors: Sand Tan, Gray, White or Black.

EVOLUTION—SPECIFIER

BIN BARS



Standard Bin Bars are painted steel. ESD Bin Bars are stainless steel with grounding kit included.

WORKSTATION WIDTH	STANDARD	ESD	WT.
48"	407121	407126	3
60"	407122	407127	4
72"	407123	407128	5

PARTS BINS

Inside Dimensions



*PART #	L	W	H	CARTON QTY	WT
ACC30210_	4-3/4"	3-1/2"	2-1/2"	24	10
ACC30220_	6-3/4"	3-1/2"	2-7/8"	24	10
ACC30230_	10-1/4"	4-3/8"	4-3/4"	12	10
ACC30240_	14"	14-3/4"	6-3/4"	6	10

*Specify color preference with a suffix to the product number:
 Only one color per carton may be ordered.
 Standard Bin Colors: **Y** = Yellow, **B** = Blue, **R** = Red

ESD PARTS BINS

Inside Dimensions

*PART #	L	W	H	CARTON QTY	WT
ACC4452	4"	3-1/2"	2-1/2"	1	1
ACC4453	6"	3-3/8"	2-1/2"	1	1
ACC4454	9"	4-3/8"	4-3/8"	1	1

ESD Bins are available in Black only.

EVOLUTION—SPECIFIER

TOOL BARS

Tool Bars are painted steel. Task Lights and Tool Bars may be mounted on one support kit.

Include (1) set of supports for each tool bar.



WORKSTATION WIDTH	PART #	WT.
48"	407111	4
60"	407112	5
72"	407113	6

DESCRIPTION	PART #	WT.
Light / Tool Bar Support Kit	407095	3

TOOL BAR TROLLEY

Tool Bar Trolleys include an eye bolt to accept a variety of tool balancers

DESCRIPTION	PART #	WT.
Tool Bar Trolley	407115	1

FOOTRAILS

Footrails are painted steel tube and feature height & depth adjustment.

DESCRIPTION	PART #	WT.
48" (W) Footrail	407081	10
60" (W) Footrail	407082	15
72" (W) Footrail	407083	20
Portable Footrest	FT-10007-01	11

EVOLUTION—SPECIFIER

TACK PANELS

12" (H) Tack Panels are mounted in-between columns. Fabric is color-coordinated with accent strip. Support bracket included.

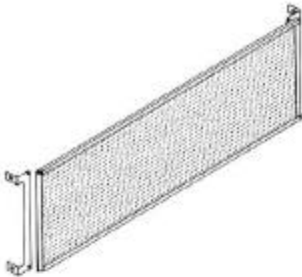

WORKSTATION WIDTH	*PART #	WT.
48"	407181_	18
60"	407182_	22
72"	407183_	26

*Specify color preference with a suffix to the product number:

Accent colors: **A** = Almond, **BK** = Black, **W** = Wineberry
B = Blue, **G** = Gray

COLUMN BASES

ESD Columns are supplied with grounding kit.

BASIC COLUMN KITS with BASES



MAXIMUM WORK-STATION HEIGHT	*STANDARD	*ESD	WT.
30" (H) Low Column	407011_	407001_E	20
36" (H) Mid Column	407012_	407002_E	22
76" (H) High Column	407010_	407000_E	36

DOUBLE-SIDED COLUMN KITS with BASES



MAXIMUM WORK-STATION HEIGHT	*STANDARD	*ESD	WT.
30" (H) Low Column	407016_	407006_E	29
36" (H) Mid Column	407017_	407007_E	31
76" (H) High Column	407015_	407005_E	45

Specify color preference with a suffix to the product number:

Accent colors: **A** = Almond, **BK** = Black, **W** = Wineberry
B = Blue, **G** = Gray

ESD Accent Colors: **A** = Almond, **G** = Gray

EVOLUTION—SPECIFIER

ACCESSORIES



DESCRIPTION	*PART #	WT.
Tool Holder	407260	1



DESCRIPTION	*PART #	WT.
Kimwipe Holder	ACC7001	1



DESCRIPTION	*PART #	WT.
Dual Solder Spool	ACC7002	1



DESCRIPTION	*PART #	WT.
Bottle Holder	ACC7004	1

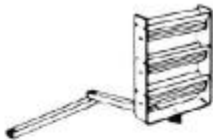

DESCRIPTION	*PART #	WT.
Articulating Bin Rack	407625	11

Reference CD index for Monitor Arms & CPU Holders



DESCRIPTION	*PART #	WT.
Articulating Solder Station	407630	8

Reference CD index for Monitor Arms & CPU Holders



DESCRIPTION	*PART #	WT.
Articulating Monitor Platform	407635	10

Reference CD index for Monitor Arms & CPU Holders

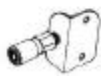

DESCRIPTION	*PART #	WT.
Quick Air Disconnect	407090	1

EVOLUTION—SPECIFIER

ESD OPTIONS

Reference the CD index section on ESD Products for more options.



The Wrist Strap Grounding System provides grounding of two wrist straps using a common point ground to ground. It measures 3" x 1-1/2" and mounts easily on the bench. (2) built-in banana jacks and 10 ft. grounding cord are included.

DESCRIPTION	*PART #	WT.
Wrist Strap Grounding Kit	990519	1



The Wrist Strap ensures all-around skin contact and electrical conductivity. 5 ft. coiled cord included.

DESCRIPTION	*PART #	WT.
Wrist Strap	990517	1

For use with Bin Bars & Shelves

DESCRIPTION	*PART #	WT.
Accessory Grounding Kit	407200	1

DESCRIPTION	*PART #	WT.
Drawer / Cabinet Ground Kit	407201	1

ESD SHELF MATS

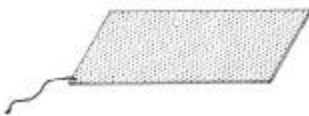

ESD Shelf Mats are used when a static dissipative surface is desired on a shelf. All necessary grounding hardware included.

DEPTH	WIDTH	*STANDARD	WT.
12"	48"	407206_	2
	60"	407207_	2
	72"	407208_	2
18"	48"	407211_	2
	60"	407212_	2
	72"	407213_	2

Specify color preference with a suffix to the product number:
ESD Shelf Mat Colors: **A** = Almond, **G** = Gray

EVOLUTION—SPECIFIER

PRICING—TERMS—CONDITIONS

PAYMENT TERMS: Net 30 w/ approved credit, or Visa, Mastercard, American Express

F.O.B.: Factory

SHIPPING: Customer to specify carrier whenever possible. All shipments sent Freight Collect.

DELIVERY: 2-4 weeks on most items. CPS will confirm delivery dates based upon production schedules.

ORDER CONFIRMATION

Orders placed are not scheduled for production or shipment until a written purchase order is received by Custom Products & Services, Inc. All purchase orders will be acknowledged and part number or price discrepancies will be noted. Corrections must be made and resubmitted to CPS prior to order being placed into production.

DAMAGE IN TRANSIT

Customer should inspect shipment upon receipt. All loss or damage claims must be made against the carrier. No claims or damages may be deducted from the invoice.

RETURNS

Returned merchandise will not be accepted unless first authorized by Custom Products & Services, Inc. A 20% restocking charge, plus repair and calibration, and any freight charges may be applied to any return shipment.

ASSEMBLY

Most workbenches and related furniture requires some assembly. Manuals will be supplied with each shipment. CPS can provide contract assembly at customers request.

Be certain to follow the directions found in the product specifier when ordering to insure you have provided paint colors (where required), wiring harnesses and other items required to complete the assembly.

Custom Products & Services, Inc.

6140 Claude Way E.

Inver Grove Heights, MN 55076

PH: 888-444-1202 (or) 651-452-0113

FAX: 651-452-2264

E-Mail: info@custom-products.com

Website: www.custom-products.com