

TECHNICAL DATA SHEET - Jumbo 2000™ Wall Mount

Solid Solutions - Solid Support™

**MODELS: JMW 2650H, JMW 2650HS, JMW 2660H,
JMW 2660HS, JMW 2665H, JMW 2665HS,
JMW 2670H, JMW 2670HS, JMW 2675H, JMW 2675HS**



The Jumbo 2000™ Wall Mounts completely surround and trap the monitor in place allowing for safe tilt up to 30°. Quick connect assembly allows upper portion of mount to be set first, then lower bracket lifts into place for easier installation.

Features:

- 0° to 30° adjustable tilt, 360° swivel
- Top and front roll out protection
- Height and width adjustable to exact dimensions of monitor
- Available for 25" to 42" TV's or monitors (check dimensions for compatibility)
- VCR mount can be added after installation
- Double Stud Wall Arm
- Hardware for mounting to wood stud wall
- Heavy gage steel construction
- Scratch resistant black or silver fused epoxy finish

Accessories:

- Security fasteners model #ACC 502
- Safety belt model #ACC 666
- VCR mounts
- Alligator® concrete anchors model #ACC 204
- Bumper guards model #ACC 103
- Wall support plates
- Video conferencing shelf model #ACC 308
- Power Buddy Hoist model #JMB 100
- Oversized roll out protectors model #ACC 016

Dimensions:

For dimensions and weights, see page 2.

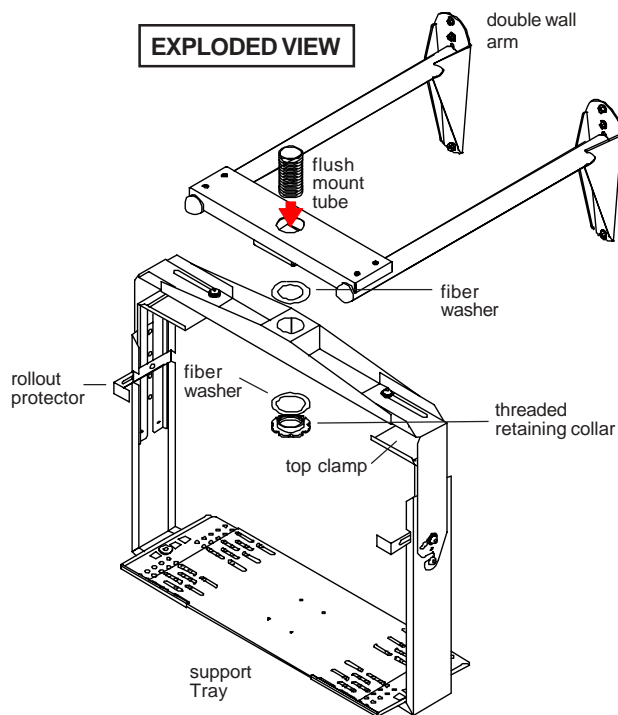

ARCHITECTSSPECIFICATIONS:

The Television Mounting Bracket shall be a CPS model _____ and shall be mounted where indicated on the plans. It shall feature adjustable height and width with top clamps and rollout protectors. It shall be constructed primarily of 14 gauge cold rolled steel and finished in black or silver fused epoxy. It shall be U.L. Listed. Assembly and installation shall be done according to the instructions provided by the manufacturer.

TECHNICAL DATA SHEET

MODELS: JMW 2650H, JMW 2650HS, JMW 2660H, JMW 2660HS, JMW 2665H, JMW 2665HS, JMW 2670H, JMW 2670HS, JMW 2675H, JMW 2675HS

Shipping Carton dimensions:

L= 36.75(934) W= 15(381) H= 9.875(251) **Maximum Load Capacity: 300 lb (136 kg)**

All Dimensions: $\frac{\text{inch}}{\text{mm}}$

JUMBO WALL MOUNT KIT - SPECIFICATIONS							
Product Weight	Shipping Weight	Model Number	BRACKET INSIDE DIMENSIONS		Tray Depth L	*1" INCREMENTS	
			Width (W)	Height (H)		Range (A)	
38 lb (17.2 kg)	44 lb (20 kg)	JMW 2650H, JMW 2650HS	24" - 31" (610 mm) (787 mm)	19.2" - 25.4" (361 mm) (518 mm)	10" (254 mm)	28" - 31" (711 mm) (787 mm)	
51 lb (23.1 kg)	55.5 lb (25.2 kg)	JMW 2660H, JMW 2660HS	29" - 36" (737 mm) (914 mm)	24.2" - 30.4" (614 mm) (772 mm)	14" (356 mm)	28" - 34" (711 mm) (864 mm)	
50 lb (22.7 kg)	52.5 lb (23.8 kg)	JMW 2665H, JMW 2665HS	29" - 36" (737 mm) (914 mm)	19.2" - 25.4" (488 mm) (645 mm)	14" (356 mm)	28" - 34" (711 mm) (864 mm)	
53.5 lb (24.3 kg)	59 lb (26.8 kg)	JMW 2670H, JMW 2670HS	34" - 41.25" (864 mm) (1048 mm)	29.2" - 35.4" (742 mm) (900 mm)	14" (356 mm)	28" - 34" (711 mm) (864 mm)	
51 lb (23.2 kg)	58 lb (29.5 kg)	JMW 2675H, JMW 2675HS	34" - 41.25" (864 mm) (1048 mm)	24.2" - 30.4" (615 mm) (772 mm)	14" (356 mm)	28" - 34" (711 mm) (864 mm)	

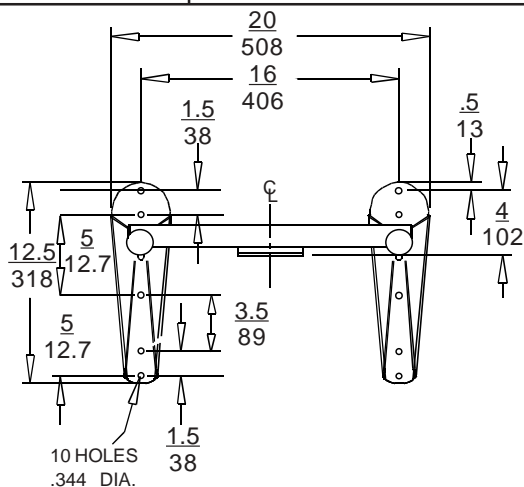

FRONT VIEW
DOUBLE WALL ARM

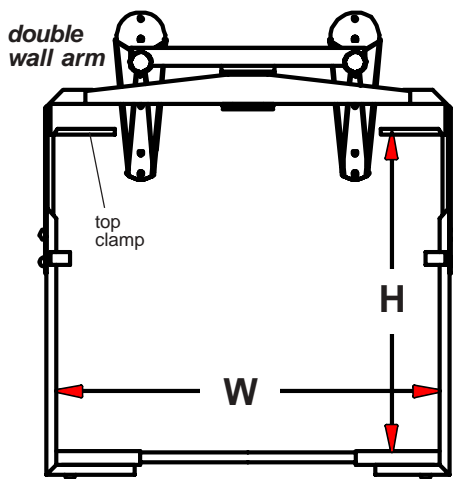

FRONT VIEW
JUMBO MOUNT WALL KIT

*1" INCREMENTS DEPENDING ON CENTER OF GRAVITY

Model Number	Height Range (H)	Overall Drop (D)
JMW 2650H (D3)	19.2 - 21.2 (488-538)	32.0 (813)
JMW 2650HS (D2)	21.3 - 23.3 (541-592)	34.0 (864)
JMW 2665H (D1)	23.4 - 25.4 (594-645)	36.0 (914)
JMW 2665HS		
JMW 2660H (D3)	24.2 - 26.2 (615-665)	37.25 (946)
JMW 2660HS (D2)	26.3 - 28.3 (668-719)	39.25 (997)
JMW 2675H (D1)	28.4 - 30.4 (721-772)	41.25 (1048)
JMW 2675HS		
JMW 2670H (D3)	29.2 - 31.2 (742-792)	42.5 (1080)
JMW 2670HS (D2)	31.3 - 33.3 (795-846)	44.5 (1130)
(D1)	33.4 - 34.4 (848-874)	46.5 (1181)

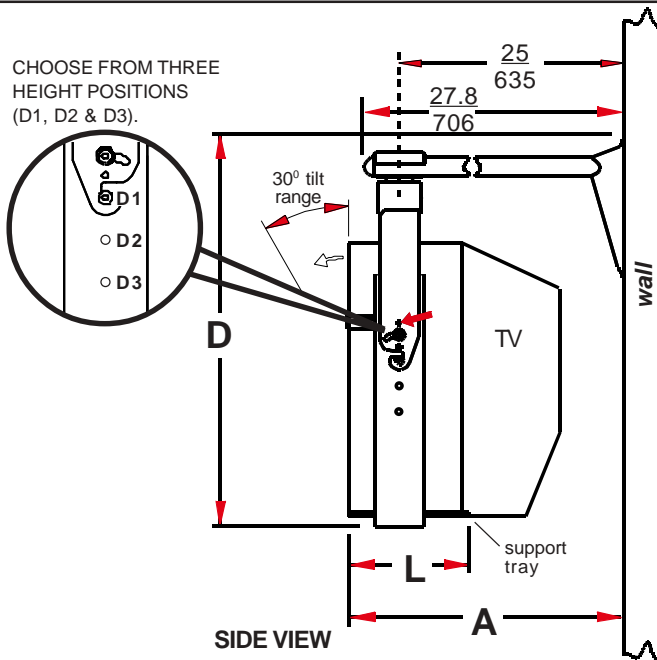

SIDE VIEW

Custom Products & Services, Inc.
6140 Claude Way E., Inver Grove Hts., MN. 55076
(PH) 651-452-0113 888-444-1202 Fax 651-452-2264
www.custom-products.com

ISSUED: 02-25-99 SHEET NO: 128-9552-5 12-28-04