



Custom Products & Services, Inc.
6140 Claude Way E.
Inver Grove Heights, MN. 55076

PH: 888-444-1202 (Toll Free) or 651-452-0113 FAX: 651-452-2264

E-MAIL: info@custom-products.com
WEBSITE: www.custom-products.com

"Your source for workplace solutions"

INTRODUCTION

These instructions and procedures have been prepared as part of a comprehensive program for the training and subsequent certification of parties installing Powerflor USA Cable Management Systems. Powerflor USA strives to provide its customers with the most advanced cable management systems on the market. Systems that meet the client's requirements initially and into the future. One of the most important aspects of meeting this goal is providing a consistent and professional installation.

Powerflor USA, Inc. will honor its product warranty, only if the system has been installed by a Powerflor USA Certified Installation company. Certification is obtained by having at least one, field supervisory staff member, complete the factory sponsored training. It is the responsibility of every Certified Powerflor USA Installation company, to maintain at least one certified supervisory staff member, and that this staff member be present on every installation, to assure that the system has been handled and installed properly.

A Powerflor USA Cable Management System provides products and services across several different areas of expertise. Installation of the systems requires learning and working with carpet tiles, pre-manufactured electrical systems, Data/Comm outlets and cabling, as well as some basic mechanical and carpentry skills.

Training and subsequent certification will be complete in every way possible. Training will include a review of all procedures and instructions for the handling and installation of all Powerflor USA products. Training will also cover possible future work, such as reconfigurations, additions, changes, and relocations of an existing project.

Certified Installation companies will be responsible for providing certain tools and supplies to complete Powerflor installations. Please review the Tools & Supplies section of this manual.

Every effort has been made to cause our training to be complete. However, every installation has the potential of being different. Powerflor USA remains committed to providing a complete system, which includes a professional installation. If you have any questions, contact our offices for instructions or assistance.

Powerflor USA, Inc. reserves the right to make product revisions and improvements at any time, that may affect the installation procedures as stated herein. Powerflor USA will make every effort possible to keep its certified installers apprised of any changes to this manual or its installation procedures.

TABLE OF CONTENTS

Section 1	Getting Started
Section 2	Recommended Tool & Supply List
Section 3	Product Receiving & Staging Procedures
Section 4	Sub-Floor Inspection & Preparation
Section 5	Installing Foam Underlay
Section 6	Panel Layout & Installation
Section 7	Installing Perimeter
Section 8	Installing Ramps & Railings
Section 9	Installing Electrical System
Section 10	Installing Data / Comm Systems
Section 11	Completing the Project
Section 12	Recessed Floors
Section 13	Replacing Carpet Tiles
Section 14	Outlet Service & Relocation

Getting Started

The cornerstone of any Powerflor installation is the Project Drawing. A sample of a Powerflor drawing is included herein for your review, and is referenced many times throughout this manual, as a sample. Before starting any project, you must obtain a copy of the Project drawing. They are available in both printed and electronic formats for your use. In the header block of the drawing, you will see a Project number. You will need to refer to this number in any communications with the factory.

The project drawing will illustrate quantity and configuration of ramp / rail access points, building connection points for electrical and Data / Comm, as well as a complete product layout. A review of the project drawing will assist you in determining the tools and supplies you will be required to provide.

During the specification and procurement phases of the project, the customer was informed of the preparation elements that need to be addressed for an installation to commence. Following are some of those basic or general points;

Levelness of Sub-Floor – The Powerflor chase way floor is not a corrective floor and cannot be leveled to correct any un-levelness of the sub-floor. Powerflor will telegraph the levelness of the sub-floor as it exists. It is recommended that the sub-floor be level within 1/8" +/- (3.18 mm) per 10'-0" of horizontal distance. This is not a requirement, and the client has been informed that Powerflor can be installed on any sub-floor deemed acceptable to them, for a normal carpet installation. If you determine that the sub-floor is considerably out of level, check with the client for acceptability of the sub-floor prior to starting your installation.

Electrical – The Single Ended power input cable assemblies are to be installed by a **licensed electrical contractor**. It is recommended that these cables be located and provided to the appropriate party as soon as possible. In some instances, these cable assemblies have been provided in advance of your installation, and may have been previously installed, awaiting your connection to the balance of the system.

Existing Carpeting & Cove Base – Carpeting and Vinyl Cove base must be removed prior to the start of an installation. This typically, is not an issue for new construction, but can be for those installations that are renovations or additions to existing spaces. If upon arrival, you determine that these elements have not been removed, you need to advise the client of this requirement. Baseboard moldings are also typically removed, however if client determines that they remain, they must provide a smooth even vertical surface, 3" in height minimally, to provide an acceptable edge for the Powerflor system.

RECOMMENDED TOOL & SUPPLY LIST

TOOL REQUIREMENTS

The following is a list of tools that will be required to perform a complete an professional installation.

1. Band Saw with 12" throat (1 Horsepower recommended)
2. Extra blades - 6 TPI - Teeth per Inch Recommended (see Picture 2-1 & 2-2)
3. Electric Drill Motor (7 amp or better) to drill concrete and steel (hammer and conventional)
4. 4" hole saw & 2" hole saw
5. 3/8" masonry bit 8" minimum length
6. 1/4" masonry bit 6" minimum length
7. 1/4" steel bit 6" minimum length
8. Counter sink drill bit
9. 4" hand grinder (see Picture 2-3)
10. Jig saw w/metal blades
11. Dremell tool
12. Vacuum cleaner
13. Tape measure or stick ruler
14. Rubber mallet
15. Carpet knife w/razor blades (see Picture 2-4)
16. Chalk line w/chalk
17. Carpenter's Framing Square (one side at least 18")
18. Putty knife
19. Screwdrivers (standard – large) (Phillips – very small)
20. Ratchet with 4" extension and socket to fit bolt anchors
21. Tin snips
22. Extension cord
23. Scissors
24. Goggles
25. First aid kit
26. Calking gun
27. Broom
28. Labeling machine w/batteries & labeling tape (see Picture 2-5)

Picture 2-1

Example 12" Band Saw



Picture 2-2

Example 12" Band Saw



Picture 2-3

4" Hand Grinder



Picture 2-4

Standard Carpet Knife



Picture 2-5

Example Labeling Machine for Data Cables



SUPPLY REQUIREMENTS

The following items are consumables and may not be required for every project. As projects vary and change these items are highly recommended to have on hand at all times.

1. ¼" x 2 ½" toggle bolts
2. ¼" x 1" wall anchor
3. ¼" x 1" screws
4. 3/8" x 2 ½" bolt anchors
5. 4 ½" x ¼" and 2 ½" x ¼" sleeve anchors
6. Nail anchors
7. Washers for ¼" screw
8. Concrete Floor Patch Material (Flash Patch)
9. Roll of duck tape
10. 1" paint brush
11. Contact adhesive (1 pt)
12. Colored electrical tape for power cables (at least 5 different colors)
13. Permanent marking ink pins
14. 8" tie wraps
15. Black magic marker
16. Black spray paint
17. Knee pads
18. Black ink pen
19. Trash bags

PRODUCT RECEIVING & STAGING PROCEDURES

- 1) Upon arrival at the installation site, insure that the location of the installation is ready to receive the Powerflor system. It is highly recommended all construction phases be complete prior to installing Powerflor. Sometimes this just cannot happen, however, at a minimum, if new walls are being built in the area. The drywall must be installed (not just the studs) so the Powerflor can be cut to fit and the floor secured in place.
- 2) Determine the location the Powerflor products are to be staged and the best route from the place of unloading to the staging area. The product should be staged in the area where it is to be installed and on the opposite side of the room where the installation will begin. If this is not possible, stage the product as close to the installation room as possible.
- 3) Unload and prepare the equipment to move the product to the staging area. It is recommended the product be left on pallets when moved to the install area or room. This will cut down on labor and time. If you must take the product off the pallets in order to move, dollies and commercial bins are recommended.
- 4) Upon arrival of the product, unload the product and get the truck ready for departure in the most expeditious manner as possible.
- 5) Confirm pallet count and inspect the product for damage. Any visual damage should be noted on the bill of lading and reported as soon as possible. Any missing pallets should be reported immediately and noted on the bill of lading.
- 6) Sign off on the shipping paperwork and retain one copy.
- 7) Move the product to the staging area, separate and stage like items together for easy access. (see Pictures 3-1, 3-2, & 3-3)
- 8) Secure product and secure all equipment.

Picture 3-1

Receiving and Staging Procedures



Picture 3-2

Receiving and Staging Procedures



Picture 3-3

Receiving and Staging Procedures



SUB-FLOOR INSPECTION & PREPARATION

- 1) It is advisable to briefly inspect the entire area where the system is to be installed. Comparing general wall locations with the drawing, confirming overall dimensions, door locations, etc. It is also advisable to be aware of any low ceiling height areas, you are adding three inches of height with the Powerflor system.
- 2) The client has been advised that the Powerflor system requires a smooth sub-floor surface. Closely inspect any sub-floor areas, that have cracks, holes or sunken areas, which would prevent the installation. Specific holes or uneven slab joints may require flash patching. Also look for other minor protrusions or obstructions, which may require scraping or grinding. Do not confuse these conditions with the overall levelness of the sub-floor. Any condition that would prevent the panels from setting firmly and evenly on the sub-floor would need to be addressed. If these conditions are minimal, it is advisable to correct them as part of the installation. If they are excessive, they need to be addressed with the client.
- 3) Also check for excessive moisture or water standing on the installation site. The Powerflor system should not be installed if these conditions exist.
- 4) Insure you have completed walls to fit the Powerflor system against, at all system termination edges. If construction is underway, and a wall is being built, you must, as a minimum, have the studs covered with drywall or finish surface material. You cannot install Powerflor against exposed studs; except for planned applications of this type.
- 5) Insure that all structures, pipes, drains or other obstacles that are protruding up through the system flooring, are shown on the project drawing. These items require the appropriate flooring components for cut to fit, in the field, application.
- 6) Sweep and remove all dust and dirt, from the floor. Insure all wall plaster or similar left over construction debris has be removed. (see Picture 4-1)

Picture 4-1

Sub-Floor Inspection

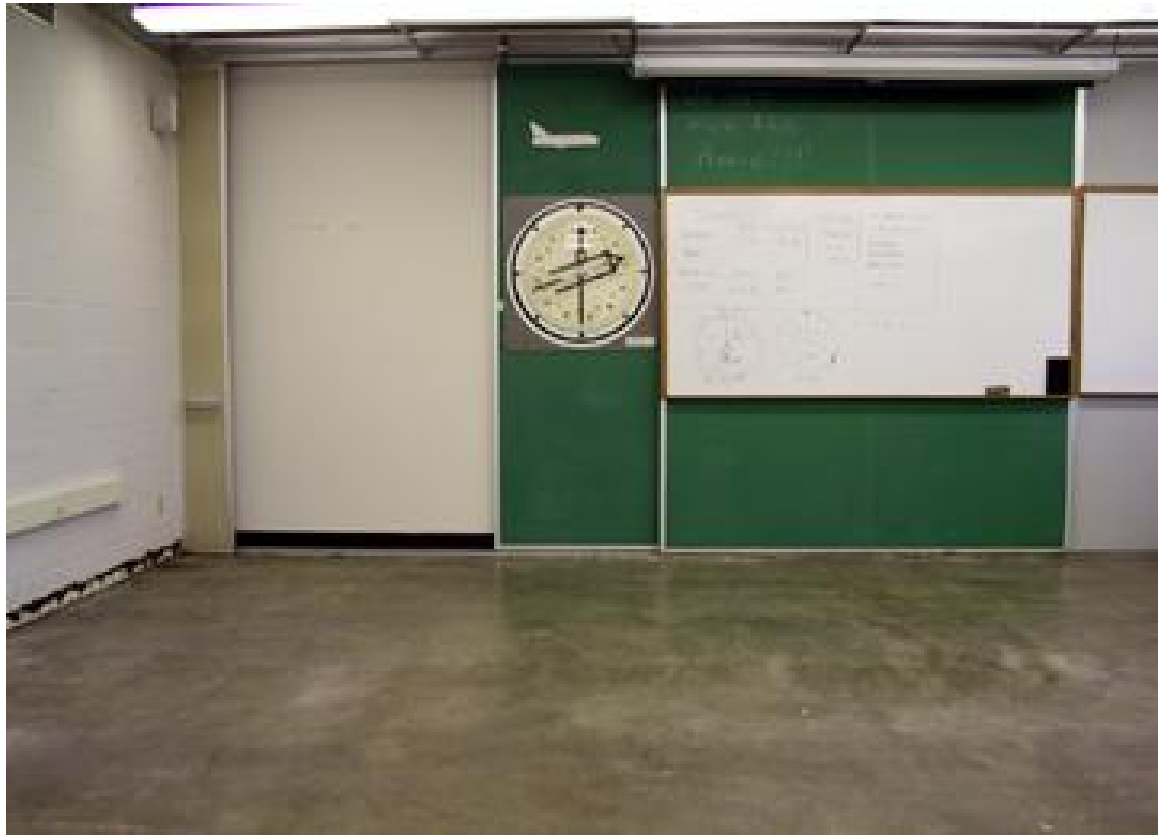

INSTALLING FOAM UNDERLAY

- 1) The Volara foam padding will be laid on all surfaces where the Powerflor system is to be installed.
- 2) The padding has two purposes. First, the foam cushions the panels and prevents clicking on hard surface sub-flooring. Second, the panel pedestal legs mark the foam to make it easier for power and data cabling to be installed.
- 3) The foam will be laid in a manner that allows the entire floor surface to be covered. It is very important to lay the foam close to all walls and columns, etc. The reason for this close fit is to give the same cushion and shim base as the rest of the floor. This will allow the carpet on the trim work to have a smooth and even fit. The foam must not be allowed to overlap, as it will cause a rise in the panel.
- 4) Panels can be used to hold the foam in place, while it is being rolled out and cut.
- 5) It is advisable to lay the foam just in front of those areas where you are placing floor panels, and avoid laying the foam in a whole room first, then placing the panels. This will help prevent debris and dirt development on top of the foam, which can obstruct panel placement. (see Picture 5-1 & 5-2)
- 6) Foam will not be laid on areas where system floor components are not being used such as under ramps, rails and Z trim.

Picture 5-1

Installing Foam Underlay



Picture 5-2

Installing Foam Underlay



PANEL LAYOUT & INSTALLATION

- 1) The starting point for laying the panels is predetermined and shown on the drawing with an “X”. (see Detail Plan P - Detail P1)
- 2) The carpet tile grain direction is also predetermined and shown on the drawing, for laying the panels, (see Detail Plan P – Detail P2). The carpet tile grain is also indicated on each panel as a yellow arrowhead marked on the legs. (see Picture 6-1)
- 3) When it is possible, the starting point will be in a corner where a right angle is formed. If the drawing indicates such a starting point, check the correctness of the right angle, as it is very important to get the floor panels started correctly. This will help keep the panels square and make a tight fitting application.
- 4) In some installations an unobstructed, right angle corner does not exist, and the full panel starting position is other than in a corner. In these cases, it is necessary for the first panel to be located on a wall, beyond the junction of an intersecting wall and the obstruction. Place the first full panel on one of the walls beyond the obstruction, at an 18” increment. Then place several additional panels, in both horizontal directions, back to the intersecting wall. Maintain the corner to corner alignment as shown on the drawing (see Picture 6-2). Field cut to fit pieces are then used to fill in around the obstruction in the corner area.
- 5) It is important to have all rows and columns placed to meet firmly and stay aligned corner to corner throughout the entire floor. As you lay the floor around obstacles, keep the panels corner to corner and fill in around the obstacle with field cut perimeter components. (see Picture 6-3)
- 6) Check tightness by measuring eleven full panels and ten joints. This measurement should be not more than 5032.38mm or 198.125 in. but no less than 5029mm or 198 in. Measurement must be identical for both the length and width.
- 7) All panels with ports for electrical and Data / Comm will be placed in the same location as shown on the drawing. Please note that each panel with a port or ports, is numbered with the port location in consideration of the carpet grain. Panels with more than one port in them will have all numeric port locations shown on it. (see Pictures 6-4, 6-5, 6-6, & 6-7)

Detail Plan P

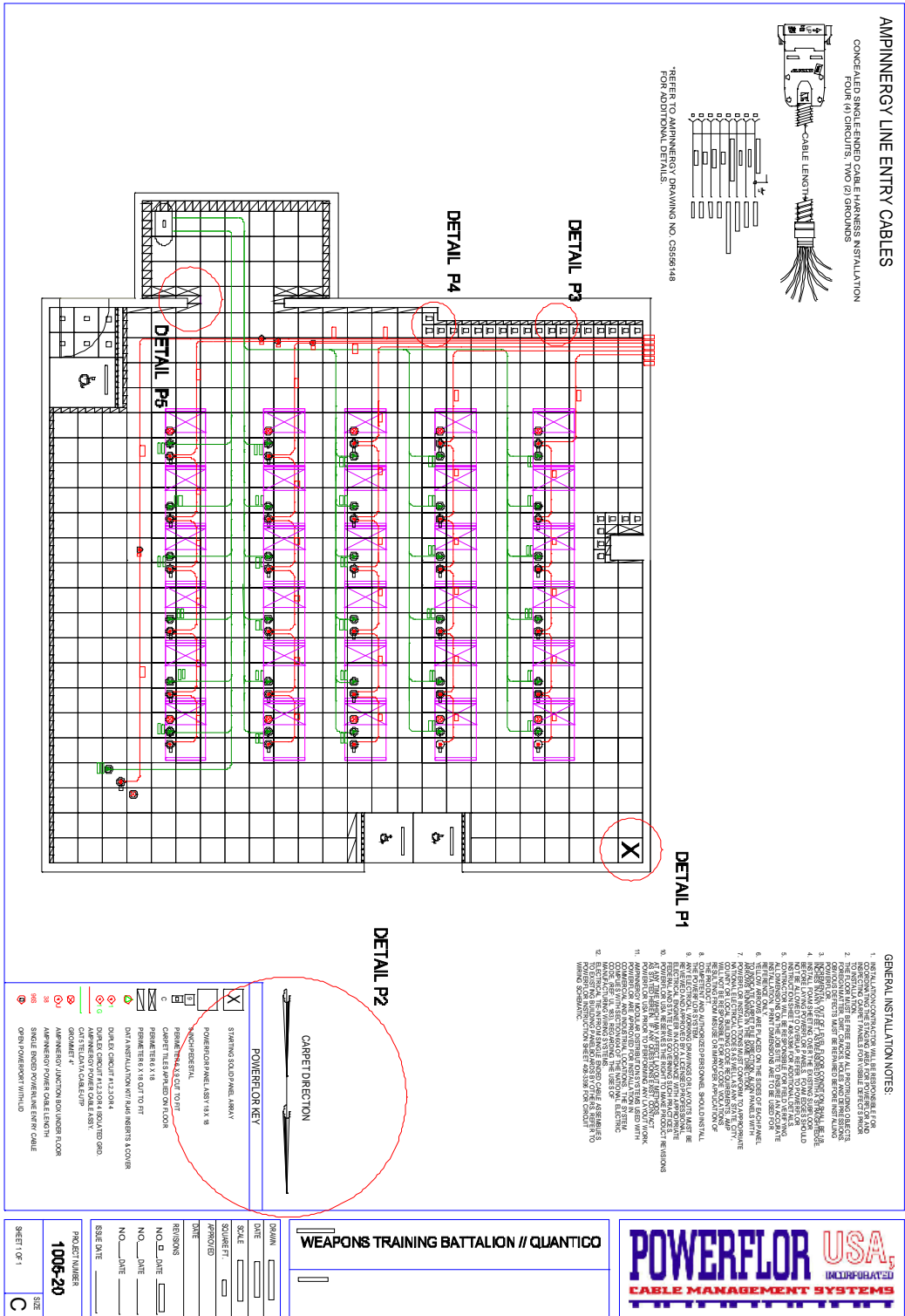

AMPIENERGY LINE ENTRY CABLES

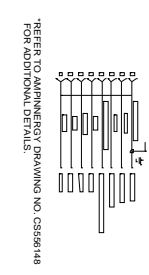
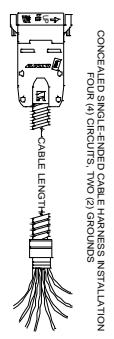

*REFER TO AMPIENERGY DRAWING NO. CS556 148 FOR ADDITIONAL DETAILS.

GENERAL INSTALLATION NOTES:

1. CONDUIT SHALL BE INSTALLED WITH A 1/2\"/>
- 2. CONDUIT SHALL BE INSTALLED WITH A 1/2\"/>
- 3. CONDUIT SHALL BE INSTALLED WITH A 1/2\"/>
- 4. CONDUIT SHALL BE INSTALLED WITH A 1/2\"/>
- 5. CONDUIT SHALL BE INSTALLED WITH A 1/2\"/>
- 6. CONDUIT SHALL BE INSTALLED WITH A 1/2\"/>
- 7. CONDUIT SHALL BE INSTALLED WITH A 1/2\"/>
- 8. CONDUIT SHALL BE INSTALLED WITH A 1/2\"/>
- 9. CONDUIT SHALL BE INSTALLED WITH A 1/2\"/>
- 10. CONDUIT SHALL BE INSTALLED WITH A 1/2\"/>
- 11. CONDUIT SHALL BE INSTALLED WITH A 1/2\"/>
- 12. CONDUIT SHALL BE INSTALLED WITH A 1/2\"/>
- 13. CONDUIT SHALL BE INSTALLED WITH A 1/2\"/>
- 14. CONDUIT SHALL BE INSTALLED WITH A 1/2\"/>
- 15. CONDUIT SHALL BE INSTALLED WITH A 1/2\"/>
- 16. CONDUIT SHALL BE INSTALLED WITH A 1/2\"/>
- 17. CONDUIT SHALL BE INSTALLED WITH A 1/2\"/>
- 18. CONDUIT SHALL BE INSTALLED WITH A 1/2\"/>
- 19. CONDUIT SHALL BE INSTALLED WITH A 1/2\"/>
- 20. CONDUIT SHALL BE INSTALLED WITH A 1/2\"/>
- 21. CONDUIT SHALL BE INSTALLED WITH A 1/2\"/>
- 22. CONDUIT SHALL BE INSTALLED WITH A 1/2\"/>
- 23. CONDUIT SHALL BE INSTALLED WITH A 1/2\"/>
- 24. CONDUIT SHALL BE INSTALLED WITH A 1/2\"/>
- 25. CONDUIT SHALL BE INSTALLED WITH A 1/2\"/>
- 26. CONDUIT SHALL BE INSTALLED WITH A 1/2\"/>
- 27. CONDUIT SHALL BE INSTALLED WITH A 1/2\"/>
- 28. CONDUIT SHALL BE INSTALLED WITH A 1/2\"/>
- 29. CONDUIT SHALL BE INSTALLED WITH A 1/2\"/>
- 30. CONDUIT SHALL BE INSTALLED WITH A 1/2\"/>
- 31. CONDUIT SHALL BE INSTALLED WITH A 1/2\"/>
- 32. CONDUIT SHALL BE INSTALLED WITH A 1/2\"/>
- 33. CONDUIT SHALL BE INSTALLED WITH A 1/2\"/>
- 34. CONDUIT SHALL BE INSTALLED WITH A 1/2\"/>
- 35. CONDUIT SHALL BE INSTALLED WITH A 1/2\"/>
- 36. CONDUIT SHALL BE INSTALLED WITH A 1/2\"/>
- 37. CONDUIT SHALL BE INSTALLED WITH A 1/2\"/>
- 38. CONDUIT SHALL BE INSTALLED WITH A 1/2\"/>
- 39. CONDUIT SHALL BE INSTALLED WITH A 1/2\"/>
- 40. CONDUIT SHALL BE INSTALLED WITH A 1/2\"/>
- 41. CONDUIT SHALL BE INSTALLED WITH A 1/2\"/>
- 42. CONDUIT SHALL BE INSTALLED WITH A 1/2\"/>
- 43. CONDUIT SHALL BE INSTALLED WITH A 1/2\"/>
- 44. CONDUIT SHALL BE INSTALLED WITH A 1/2\"/>
- 45. CONDUIT SHALL BE INSTALLED WITH A 1/2\"/>
- 46. CONDUIT SHALL BE INSTALLED WITH A 1/2\"/>
- 47. CONDUIT SHALL BE INSTALLED WITH A 1/2\"/>
- 48. CONDUIT SHALL BE INSTALLED WITH A 1/2\"/>
- 49. CONDUIT SHALL BE INSTALLED WITH A 1/2\"/>
- 50. CONDUIT SHALL BE INSTALLED WITH A 1/2\"/>
- 51. CONDUIT SHALL BE INSTALLED WITH A 1/2\"/>
- 52. CONDUIT SHALL BE INSTALLED WITH A 1/2\"/>
- 53. CONDUIT SHALL BE INSTALLED WITH A 1/2\"/>
- 54. CONDUIT SHALL BE INSTALLED WITH A 1/2\"/>
- 55. CONDUIT SHALL BE INSTALLED WITH A 1/2\"/>
- 56. CONDUIT SHALL BE INSTALLED WITH A 1/2\"/>
- 57. CONDUIT SHALL BE INSTALLED WITH A 1/2\"/>
- 58. CONDUIT SHALL BE INSTALLED WITH A 1/2\"/>
- 59. CONDUIT SHALL BE INSTALLED WITH A 1/2\"/>
- 60. CONDUIT SHALL BE INSTALLED WITH A 1/2\"/>
- 61. CONDUIT SHALL BE INSTALLED WITH A 1/2\"/>
- 62. CONDUIT SHALL BE INSTALLED WITH A 1/2\"/>
- 63. CONDUIT SHALL BE INSTALLED WITH A 1/2\"/>
- 64. CONDUIT SHALL BE INSTALLED WITH A 1/2\"/>
- 65. CONDUIT SHALL BE INSTALLED WITH A 1/2\"/>
- 66. CONDUIT SHALL BE INSTALLED WITH A 1/2\"/>
- 67. CONDUIT SHALL BE INSTALLED WITH A 1/2\"/>
- 68. CONDUIT SHALL BE INSTALLED WITH A 1/2\"/>
- 69. CONDUIT SHALL BE INSTALLED WITH A 1/2\"/>
- 70. CONDUIT SHALL BE INSTALLED WITH A 1/2\"/>
- 71. CONDUIT SHALL BE INSTALLED WITH A 1/2\"/>
- 72. CONDUIT SHALL BE INSTALLED WITH A 1/2\"/>
- 73. CONDUIT SHALL BE INSTALLED WITH A 1/2\"/>
- 74. CONDUIT SHALL BE INSTALLED WITH A 1/2\"/>
- 75. CONDUIT SHALL BE INSTALLED WITH A 1/2\"/>
- 76. CONDUIT SHALL BE INSTALLED WITH A 1/2\"/>
- 77. CONDUIT SHALL BE INSTALLED WITH A 1/2\"/>
- 78. CONDUIT SHALL BE INSTALLED WITH A 1/2\"/>
- 79. CONDUIT SHALL BE INSTALLED WITH A 1/2\"/>
- 80. CONDUIT SHALL BE INSTALLED WITH A 1/2\"/>
- 81. CONDUIT SHALL BE INSTALLED WITH A 1/2\"/>
- 82. CONDUIT SHALL BE INSTALLED WITH A 1/2\"/>
- 83. CONDUIT SHALL BE INSTALLED WITH A 1/2\"/>
- 84. CONDUIT SHALL BE INSTALLED WITH A 1/2\"/>
- 85. CONDUIT SHALL BE INSTALLED WITH A 1/2\"/>
- 86. CONDUIT SHALL BE INSTALLED WITH A 1/2\"/>
- 87. CONDUIT SHALL BE INSTALLED WITH A 1/2\"/>
- 88. CONDUIT SHALL BE INSTALLED WITH A 1/2\"/>
- 89. CONDUIT SHALL BE INSTALLED WITH A 1/2\"/>
- 90. CONDUIT SHALL BE INSTALLED WITH A 1/2\"/>
- 91. CONDUIT SHALL BE INSTALLED WITH A 1/2\"/>
- 92. CONDUIT SHALL BE INSTALLED WITH A 1/2\"/>
- 93. CONDUIT SHALL BE INSTALLED WITH A 1/2\"/>
- 94. CONDUIT SHALL BE INSTALLED WITH A 1/2\"/>
- 95. CONDUIT SHALL BE INSTALLED WITH A 1/2\"/>
- 96. CONDUIT SHALL BE INSTALLED WITH A 1/2\"/>
- 97. CONDUIT SHALL BE INSTALLED WITH A 1/2\"/>
- 98. CONDUIT SHALL BE INSTALLED WITH A 1/2\"/>
- 99. CONDUIT SHALL BE INSTALLED WITH A 1/2\"/>
- 100. CONDUIT SHALL BE INSTALLED WITH A 1/2\"/>

POWERFLOR REV

STAIRING 30\"/>

POWERFLOR MFL/ASTY 15X 18

NON-SLIP

CONCRETE FLOOR OVER

FRIBRE TERS 8 X 18 OUT TO FIT

DATA INSTALLATION WITH RAIL INVERTS & COVER

DANISO CORDIT #12.014

DANISO CORDIT #12.014 3/4\"/>

CONCRETE FLOOR OVER

GROUNDWATER

AMPIENERGY JUNCTION BOX UNDER FLOOR

AMPIENERGY POWER CABLE LENGTH

SINGLE ENDED POWER CABLE ENTRY CABLE

OPEN POWER ENTRY WINDOW

POWERFLOR REV

STAIRING 30\"/>

POWERFLOR MFL/ASTY 15X 18

NON-SLIP

CONCRETE FLOOR OVER

FRIBRE TERS 8 X 18 OUT TO FIT

DATA INSTALLATION WITH RAIL INVERTS & COVER

DANISO CORDIT #12.014

DANISO CORDIT #12.014 3/4\"/>

CONCRETE FLOOR OVER

GROUNDWATER

AMPIENERGY JUNCTION BOX UNDER FLOOR

AMPIENERGY POWER CABLE LENGTH

SINGLE ENDED POWER CABLE ENTRY CABLE

OPEN POWER ENTRY WINDOW

POWERFLOR USA

CABLE MANAGEMENT SYSTEMS

WEAPONS TRAINING BATTALION // QUANTICO

PROJECT NUMBER: 1006-20

SHEET 1 OF 1

DATE: _____

SCALE: _____













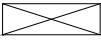
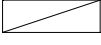

APPROVED: _____

ISSUE DATE: _____

Detail Plan P

Blow Up A / General Installation Notes

1. INSTALLATION CONTRACTOR WILL BE RESPONSIBLE FOR COORDINATING THE STAGING AREA FOR POWERFLOR AND INSPECTING CARPET PANELS FOR VISIBLE DEFECTS PRIOR TO INSTALLATION.
2. THE FLOOR MUST BE FREE FROM ALL PROTRUDING OBJECTS, FOREIGN MATTER, DIRT, CRACKS, HOLES, AND DEPRESSIONS. OBVIOUS DEFECTS MUST BE REPAIRED BEFORE INSTALLING POWERFLOR.
3. INCREMENTAL OUT OF LEVEL FLOOR CONDITION SHALL BE 1/8 INCHES IN ANY 10 FEET, AS MEASURED WITH A STRAIGHTEDGE.
4. INSTALL FOAM SHEETING OVER THE EXISTING SUBFLOOR BEFORE LAYING POWERFLOR PANELS. FOAM EDGES SHOULD NOT BE ALLOWED TO OVERLAP. REFER TO POWERFLOR INSTALLATION MANUAL FOR ADDITIONAL DETAILS.
5. CONTRACTOR WILL BE RESPONSIBLE FOR FIELD VERIFYING ALL DIMENSIONS ON THE JOB SITE TO ENSURE AN ACCURATE INSTALLATION. PRINT DIMENSIONS ARE TO BE USED FOR REFERENCE ONLY.
6. YELLOW ARROWS ARE PLACED ON THE SIDES OF EACH PANEL TO INDICATE CARPET PILE DIRECTION. ALIGN PANELS WITH ARROWS RUNNING IN THE SAME DIRECTION.
7. POWERFLOR INSTALLATIONS MUST CONFORM TO APPROPRIATE NATIONAL ELECTRICAL CODES, AS WELL AS, ANY STATE, CITY, COUNTY, OR LOCAL BUILDING CODE REQUIREMENTS. POWERFLOR USA WILL NOT BE RESPONSIBLE FOR ANY CODE VIOLATIONS RESULTING FROM MISUSE OR IMPROPER APPLICATION OF THE PRODUCT.
8. COMPETENT AND AUTHORIZED PERSONNEL SHOULD INSTALL THE POWERFLOR SYSTEM.
9. ANY ELECTRICAL WORKING DRAWINGS OR LAYOUTS MUST BE REVIEWED AND APPROVED BY A LICENSED PROFESSIONAL ELECTRICAL ENGINEER IN ACCORDANCE WITH APPROPRIATE FEDERAL AND STATE LAWS GOVERNING SUCH PRACTICES.
10. POWERFLOR USA RESERVES THE RIGHT TO MAKE PRODUCT REVISIONS AT ANY TIME WHICH MAY AFFECT LAYOUT METHODS AS STATED HEREIN. IF ANY QUESTIONS EXIST, CONTACT POWERFLOR USA PRIOR TO PERFORMING ANY LAYOUT WORK.
11. AMPINERGY MODULAR DISTRIBUTION SYSTEMS USED WITH POWERFLOR ARE APPROVED FOR INSTALLATION IN COMMERCIAL AND INDUSTRIAL LOCATIONS. THE SYSTEM COMPLIES WITH SECTION 604 OF THE NATIONAL ELECTRIC CODE, (REF: UL 183), REGARDING THE USES OF MANUFACTURING WIRING SYSTEMS.
12. ELECTRICAL TIE-IN FROM SINGLE ENDED CABLE ASSEMBLIES TO EXISTING BUILDING PANELBOARDS BY OTHERS. REFER TO AMPINERGY LINE ENTRY CABLE DETAIL ON THIS DRAWING FOR CIRCUIT WIRING SCHEMATIC.

POWERFLOR KEY	
	STARTING SOLID PANEL ARRAY
	POWERFLOR PANEL ASSY 18 X 18
	9-INCH PEDESTAL
	PERIMETER 6 X 9 CUT TO FIT
	CARPET TILES APPLIED ON FLOOR
	PERIMETER 6 X 18
	PERIMETER 6 X 18 CUT TO FIT
	DATA INSTALLATION KIT/ RJ45 INSERTS & COVER
	DUPLEX CIRCUIT #1,2,3 OR 4
	DUPLEX CIRCUIT #1,2,3 OR 4 ISOLATED GRD.
	AMPINNERGY POWER CABLE ASSY.
	CAT5 TEL/DATA CABLE-UTP
	GROMMET 4"
	AMPINNERGY JUNCTION BOX UNDER FLOOR
	AMPINNERGY POWER CABLE LENGTH
	SINGLE ENDED POWER/LINE ENTRY CABLE
	OPEN POWERPORT WITH LID

Detail P-1

		X

Detail P-2

CARPET DIRECTION



Picture 6-1 Full Panel (Showing Carpet Tile Direction)



Picture 6-2 Starting the System at other than a corner



Picture 6-3

Installing the System around obstacles



Picture 6-4

Panel with Port in # 1 position



Picture 6-5

Panel with Port in # 2 position



Picture 6-6

Panel with Port in # 3 position



Picture 6-7

Panel with Port # 4 position



INSTALLING PERIMETER

- 1) Perimeter components are used to fill in all spaces where an 18" x 18" panel is too large to fit.
- 2) Perimeter components are available in two sizes. A 9" x 9" lose pedestal and a 6" x 18" ribbed component. Only the 6" x 18" ribbed component is intended for cutting to size in the field. (see Pictures 7-1, 7-2, & 7-3)
- 3) Some areas may require multiple 6" x 18" ribbed components or 9" x 9" pedestals, while other areas may require a combination of both. (see Detail Plan P – Details P-3, P-4, & P-5) These Details are meant to illustrate the completed perimeter assembly. Perimeter components are to be cut to fit as individual components, to assure snugness of fit.
- 4) All perimeter components are provided without the carpet tile attached. Pre-Glued carpet tiles are provided for installation on these components, after they are cut and fitted into the space. This will assure a proper carpet tile installation.
- 5) When you have small areas that require perimeter, it must be cut to a custom fit. When you have areas less than one and one eighth inch ($1 \frac{1}{8}$ ") to be filled, the ribbed component should not be cut lengthwise with the rib. It must be cut perpendicular to the rib, to provide stability when installed. (see Pictures 7-4, 7-5, & 7-6)
- 6) All areas requiring perimeter to be cut, will be cut to fit snug. It should not be so loose it leaves gaps nor should it be so tight it requires extreme force to insert. The perimeter is used as a base for the carpet and helps to hold the panels in place. (see Pictures 7-7 & 7-8)

Picture 7-1

Loose 9" x 9" Pedestal



Picture 7-2

6" x 18" Perimeter (Top View)



Picture 7-3

6" x 18" Perimeter (Bottom View)



Detail P-3

Panel with combination of perimeter / pedestals

**FIELD CUT
AS REQUIRED**

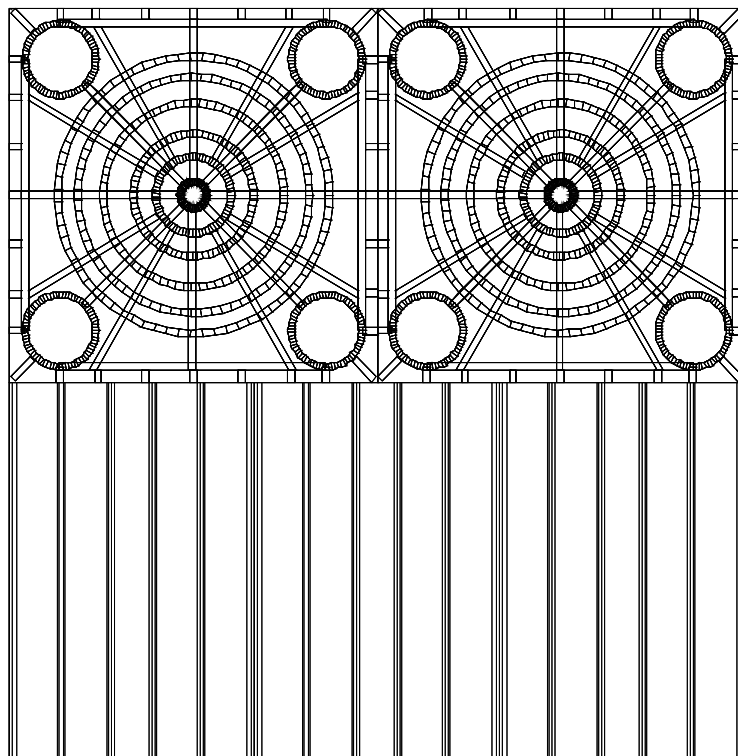
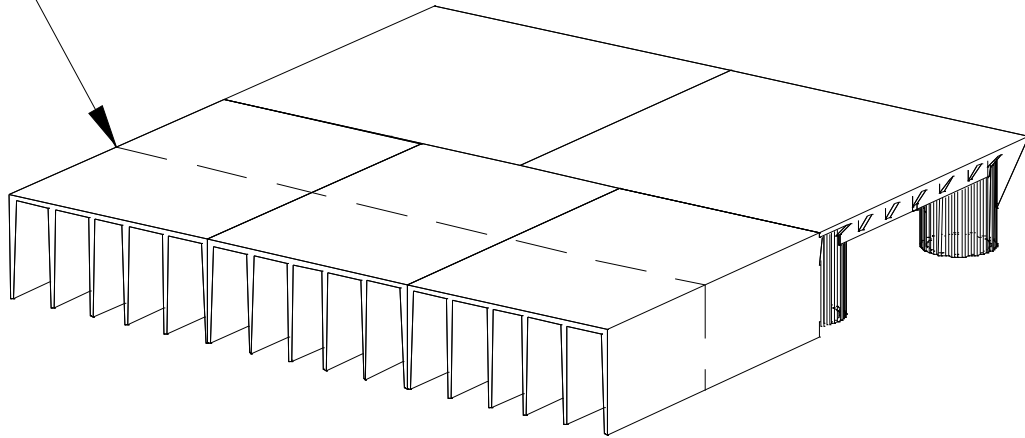

Detail P-4

Panel with combination of perimeter / pedestals

FIELD CUT
AS REQUIRED

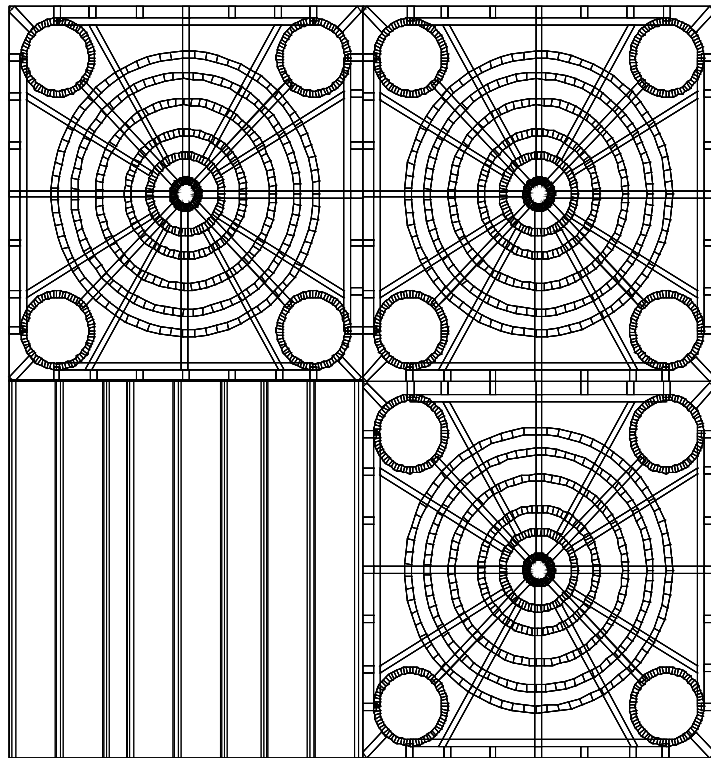
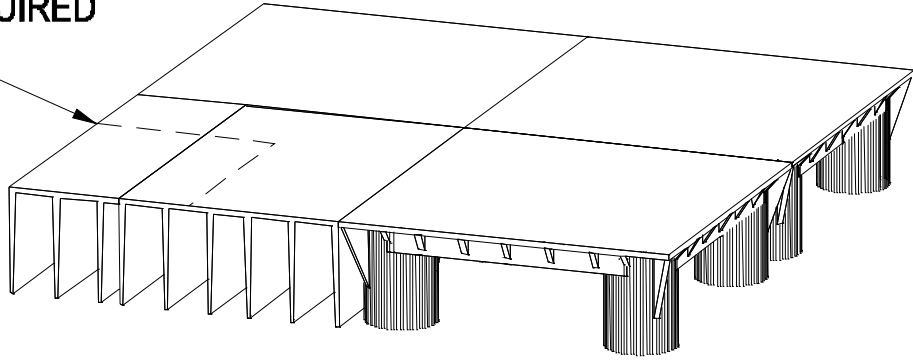

Detail P-5

Panel with perimeters only

FIELD CUT
AS REQUIRED

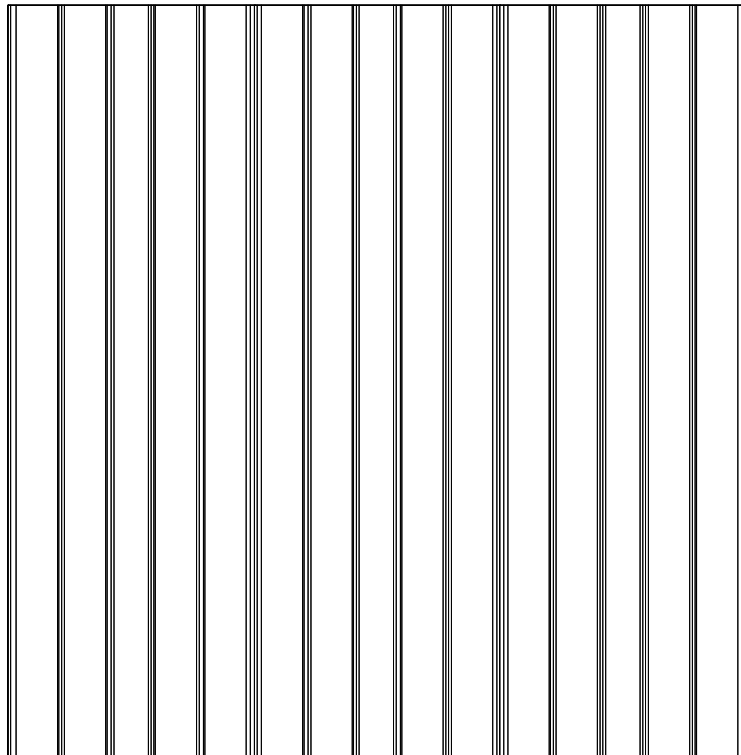
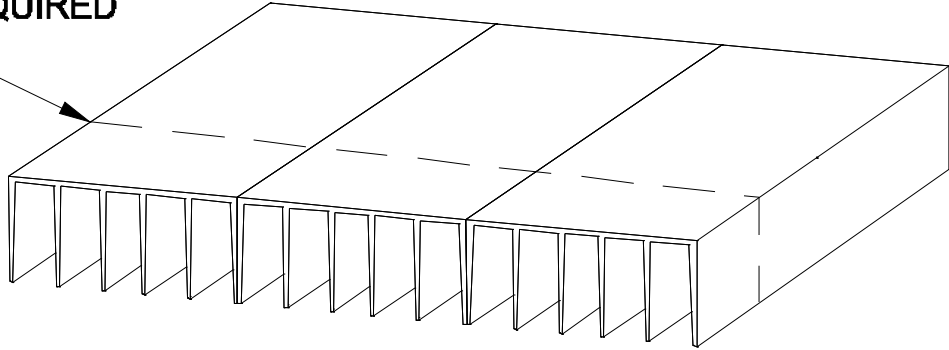

Picture 7-4
Cutting Perimeter



Picture 7-5
Cutting Perimeter



Picture 7-6 Cutting Perimeter



Picture 7-7

Filling In Perimeter around obstacles



Picture 7-8

Filling in Perimeter around obstacles



INSTALLING CARPET ON PERIMETER

- 1) Carpet will be field cut to cover the perimeter that has been installed.
- 2) All carpet cut for trim work must maintain directional integrity as shown on the drawing. Please see back of loose carpet tiles for an imprinted carpet direction arrow.
- 3) The carpet will be cut to provide a snug fit between the adjacent full panels and the wall or obstacle which you are trimming out to. It should not show any gaps, nor should it have to be forced into place.
- 4) When trimming you must maintain seam integrity of factory edge to factory edge, in both directions. All field cut edges should be made, to be located around obstructions, walls, and / or rails.
- 5) Loose pre-glued carpet tiles are provided for this procedure. These carpet tiles are provided with a protective waxed paper backing, which is removed and discarded, after cutting, and immediately prior to applying the tile to the perimeter components.
- 6) Working with the carpet tile, upside down and in place, is advisable, for the cutting procedure. This provides the most accurate templating and assures the proper fit. When cutting is complete, remove the waxed paper backing, flip the carpet tile over, and all field cut edges are against the item being trimmed to. (see Pictures 7-9, 7-10, & 7-11)

Please Note !!!

In some cases, the Powerflor system is provided using a permanent adhesive. When a PVC hard-backed carpet tile has been used, providing pre-glued carpet tiles is impossible. Applying the adhesive to the carpet tile for this procedure is done in the field, and un-glued carpet tiles are provided for this purpose.

- 1) Carpet will be field cut as described above prior to applying the glue.
- 2) All carpet cut for trim work is as described above, maintaining carpet tile grain directional integrity, seam integrity of factory edge to factory edge, and cut to provide a snug fit between the adjacent full panels and the wall or obstacle.
- 3) After the carpet tile has been cut to fit, it should be placed on a protected surface upside down, where glue is applied sprayed or brushed, per project spec.
- 4) The glue is a contact cement type glue, so it must be applied to both the back of the carpet tile and the top surface of the perimeters being covered. The containers of glue provided will provide instructions for application, drying time, and application instructions.
- 5) Care should be taken to assure that glue application is done in a good workmanlike manner, without glue getting on carpet tile face or adjacent areas.

Picture 7-9

Cutting carpet tile for perimeter



Picture 7-10

Cutting carpet tile for perimeter



Picture 7-11

Installing carpet tile on perimeter



INSTALLING Z TRIM

- 1) In some instances it is required to end the Powerflor system without a wall or other fixed building structure to act as a barrier. In these cases Z Trim is used. (see Pictures 7-12 & 7-13)
- 2) The Z Trim will be custom cut to fit the opening where it is to be installed. (see Picture 7-14) Z Trim is meant to be glued, anchored with sleeve anchors, nail anchors, or flush screwed to the sub-floor and provides a vertical edge to the system which laps over the top of the system's edge components. (see Detail P-6)
- 3) When installed, Powerflor components fit into and underneath the top flange of the Z Trim on one side and carpeting is to be installed on top of the floor attachment flange. Floor attachment must be accomplished in as flush a manner as possible, so that the carpeting over is unobstructed.

Please Note ! Carpeting beyond the Powerflor system is not normally included, so the installation of the carpeting that covers the floor attachment flange may not be part of your work scope. Check install agreement and project drawing for clarification.

- 4) Z Trim is used to brace and dress Powerflor edging along doorways and obstacles such as sliding walls, etc., where no permanent building structure exists. Z Trim is commonly used in doorways to supply rooms, communication rooms or similar joining spaces where Powerflor is not installed and ramps are not used. Z Trim is also used to dress ramp edges where a rail is not used or to end the system along other non-fixed building elements (i.e. Sliding Marker / Chalk boards, see Picture 7-15)
- 5) When Z Trim is used at doorways where ramping is not desired (see Pictures 7-16, 7-17, & 7-18) it must be installed in a manner that allows for the proper operation of the door. When door is closed, Z trim is to be located underneath the door.

Picture 7-12

Z Trim (as provided)

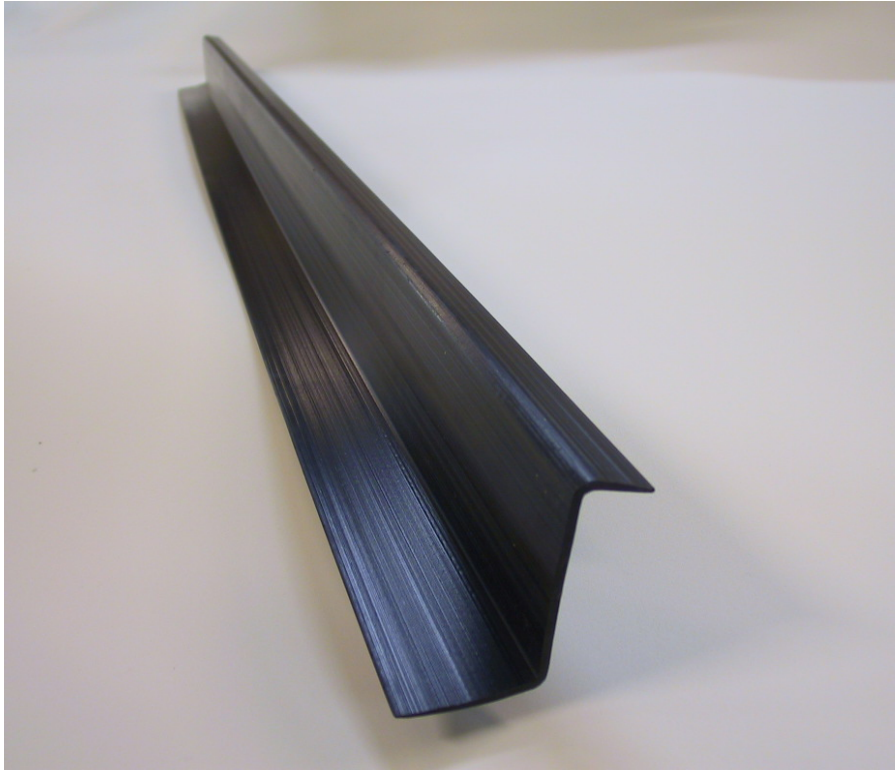

Picture 7-13

Z Trim installed at the edge of the system



Detail P-6

Detail of Z Trim with panels

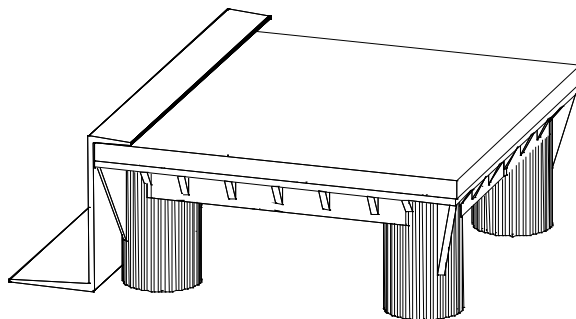
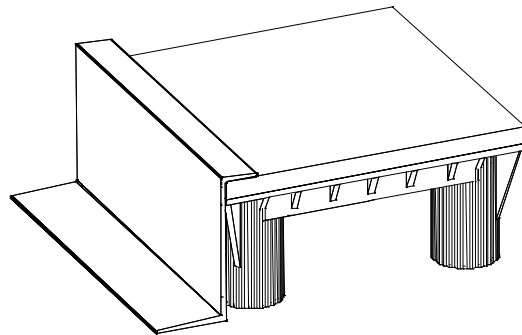
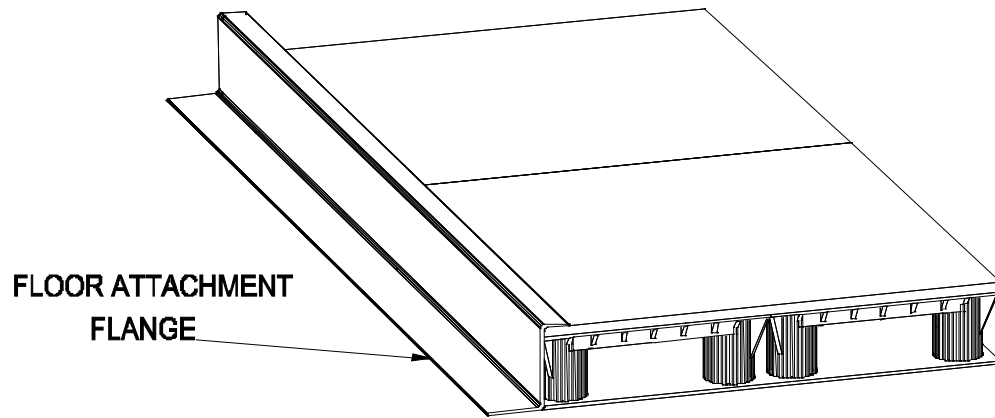

Picture 7-14 **Cutting Z Trim**



Picture 7-15 **Z Trim Installed**



Picture 7-16

Z Trim in a doorway



Picture 7-17

Z Trim in a doorway



Picture 7-18

Z Trim / Perimeters in a doorway



INSTALLING RAMPS & RAILINGS

RAMP INSTALLATION

- 1) The Powerflor system is provided with ramps for pedestrian access. These ramps are available in three different slopes.
- 2) The 1/6 slope ramp is provided as a black polycarbonate unit, 18" wide by 18" long. This ramp unit does not meet ADA codes.
- 3) The 1/12 slope ramp is 35" long and the 1/20 slope ramp is 53" long. Both the 1/12 and 1/20 sloped ramps are constructed from steel and provided in two widths, 24" and 30". Both of these ramp units meet ADA codes.
- 4) Ramp installations, may be provided as a single unit or multiple ramp units to achieve the desired overall width of the ramp access. The ramp size and type is predetermined and shown on the project drawing.
- 5) Once the ramps are located and positioned, they shall be anchored in place using 1/4" x 3" sleeve anchors in such a way that the ramp will not produce a hollow sound when walked upon. (see Picture 8-1) Additional anchors may be required to tighten the ramp at any number of locations.
- 6) When drilling holes, make sure they are counter sunk and the anchors do not interfere with the laying of carpet tiles. (see Picture 8-2)
- 7) In some instances a ramp unit may have to be field cut or small fillers added at the edges. This can occur when the ramp is to be installed between building structures (i.e. walls) that are not parallel and / or straight. When cutting the ramp width, care should be taken to locate the cut or cuts to provide maximum support (i.e. as close to the web supports as possible). If fillers are required or additional support to a cut ramp, this can be accomplished using wood fillers, cut appropriately.

Picture 8-1 Ramp Installed with Rail and Z Trim



Picture 8-2 Drilling Ramp for countersunk anchors



RAILING INSTALLATION

- 1) Ramp access to the system can be provided in a vast assortment of configurations, depending upon site conditions and client requirements. In most instances, a rail is specified next to ramps and around ramp access areas, to prevent unfinished system edges and to eliminate any tripping hazard,.
- 2) Ramp access areas and the rail layout associated with these areas are predetermined and shown on the project drawing.
- 3) Rails are provided in a standard height, with a base that accepts the Powerflor system on one side and provides a finish edge on the other side. All standard rails are provided powder coated paint finish, black in color. (see Picture 8-3)
- 4) Rails are provided in two widths, 24" and 36". These units can be used as a stand alone rails or configured in multiples to serve many different layout requirements. In some cases, rails have to be cut to meet field conditions.
- 5) All rail units can be mounted end to end, in a straight line or at right angles to one another, with connecting brackets underneath the top rail cap. (see Pictures 8-4 & 8-5). They can also be mounted to a wall by using an angle bracket in lieu of a connecting bracket (see Pictures 8-6 & 8-7).
- 6) All rail units are bolted to the sub-floor. When mounting the rail, use 3/8" x 2-1/2" bolt anchors with a washer and nut. (see Picture 8-8) Perimeter units are used to fill in around rail base (see Picture 8-9).
- 7) A freestanding rail will only require floor anchoring. However, if the rail requires wall anchoring, adjust your anchoring procedures according to the type of material you are anchoring to. If the wall is concrete or masonry block you will need to drill the wall and insert either a lead or plastic anchor. Then the "L" bracket will be attached using a cap head screw / lag. If the wall is drywall, drill the wall and attach the "L" bracket with a 1/4" x 2" toggle bolt and washer. If the wall is wood, use a cap head screw.
- 8) Insure the rail is plumb and shimmed to the wall if necessary.
- 9) All visible mounting hardware should be touched up with black paint or markers.

Picture 8-3

Rails located next to ramp



Picture 8-4 Rail Straight Splice Plate

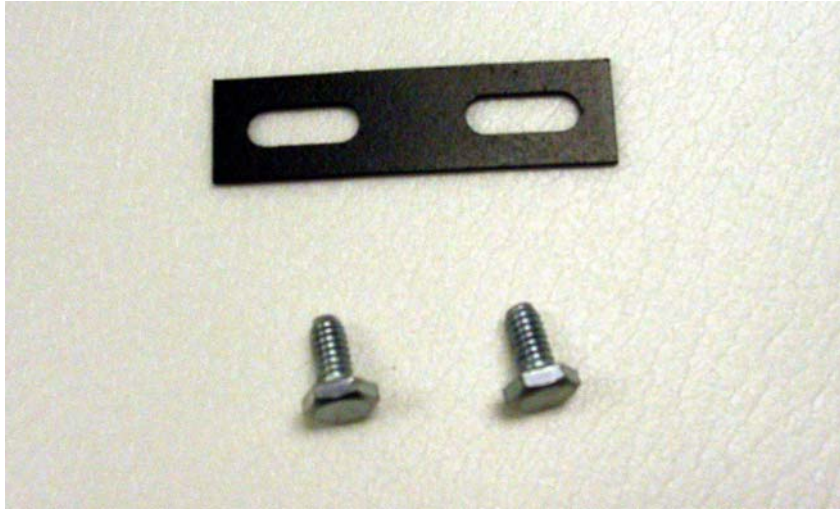

Picture 8-5 Straight Splice Plate Installed

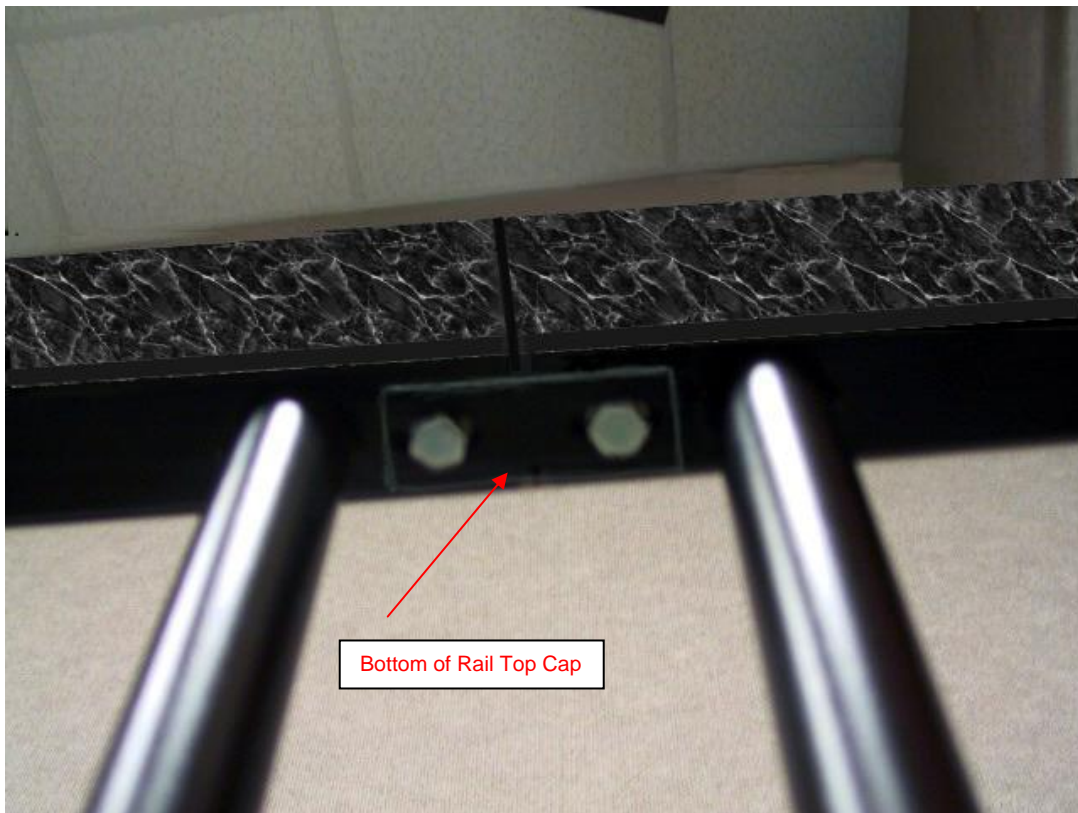

Picture 8-6

Rail Angle Plate

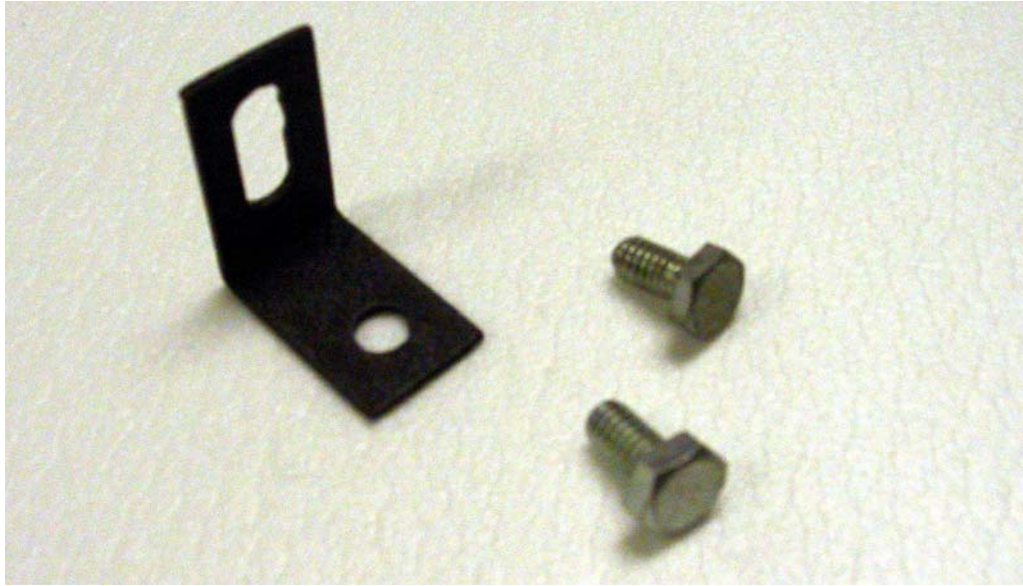

Picture 8-7

Rail Angle Plate Installed

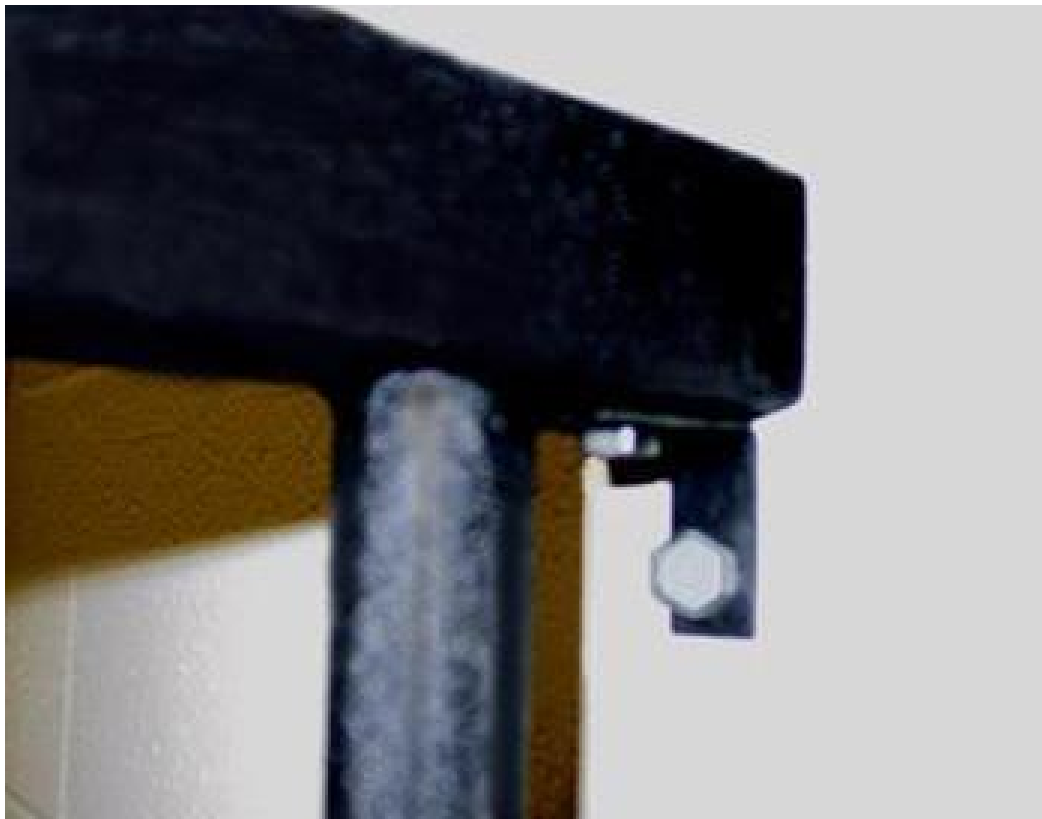

Picture 8-8 Rail anchored to floor with 2½" x 3/8" anchor bolt



Picture 8-9 Rail, Ramp, and Z Trim mounted to floor



INSTALLING CARPET ON RAMPS

- 1) Carpet will be field cut to cover the ramp unit, the rail base, and the sub-floor area approaching the ramp as per the project drawing.
- 2) All carpet cut for trim work must maintain directional integrity as shown on the drawing. Please see back of loose carpet tiles for an imprinted carpet direction arrow.
- 3) The carpet will be cut to provide a snug fit between the adjacent full panels and the rail base or Z Trim at the edge. (see Picture 8-10) It should not show any gaps, nor should it have to be forced into place.
- 4) When trimming you must maintain seam integrity of factory edge to factory edge, in both directions. All field cut edges should be made, to be located around rail base .
- 5) Loose pre-glued carpet tiles are provided for this procedure. These carpet tiles are provided with a protective waxed paper backing, which is removed and discarded, after cutting, and immediately prior to applying the tile to the ramp, rail base or sub-floor.
- 6) Whenever possible installation should be laid out so that a carpet seam does not occur at the top or bottom of ramp unit. Carpet tile seams will appear open if not made in the same plane. (see Picture 8-11)
- 7) Wherever the carpet tile ends, as per the project drawing, carpet should be terminated using a vinyl transition strip. These transition strips are provided and will provide a clean sharp transition between our carpet tiles and a hard surface floor. When our system adjoins other carpeting, the transition strip may not be used providing a clean and even transition from and onto the system.
- 8) The transition strip is a two piece unit and the base requires gluing to the sub-floor. The carpet tile is installed up to the mounting channel. And the finish strip clicks into the channel. (see Pictures 8-12, 8-13, & 8-14)
- 9) In all cases care should be used in providing a clean straight transition between the Powerflor system and all adjacent sub-floor areas.
(see Pictures 8-15, 8-16, & 8-17)

Picture 8-10 **Trimming carpet tile on ramp**

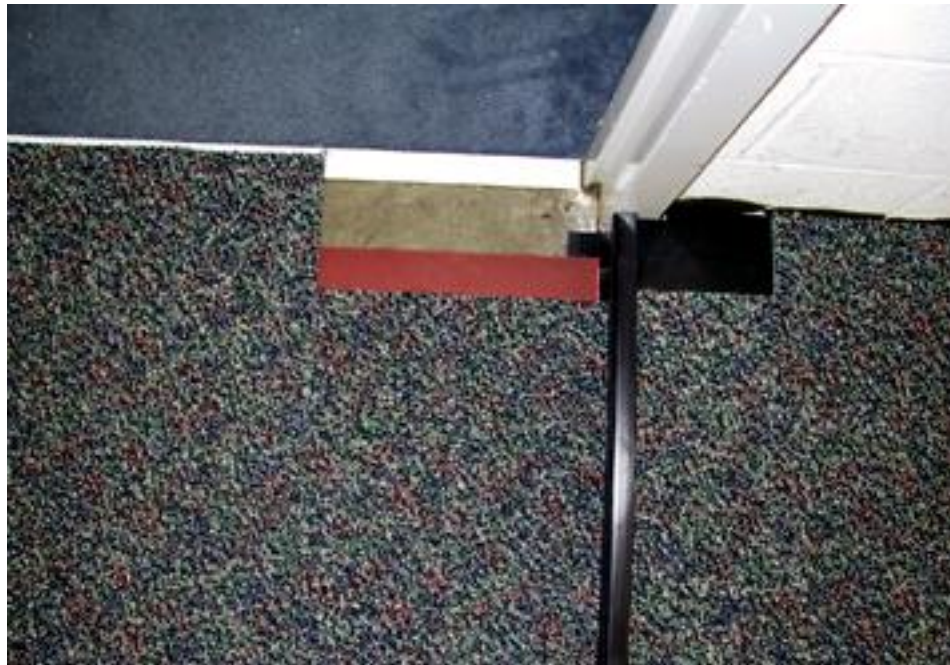

Picture 8-11 **Carpet Tile seam installed beyond top and bottom of ramp**



Picture 8-12

Transition Molding as provided

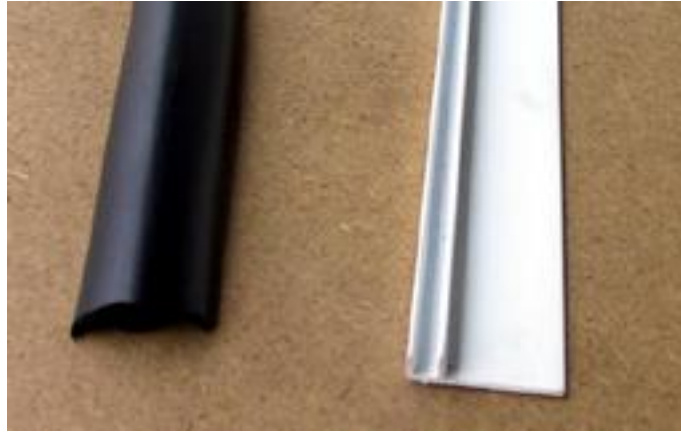

Picture 8-13

Transition molding with Carpet Tile

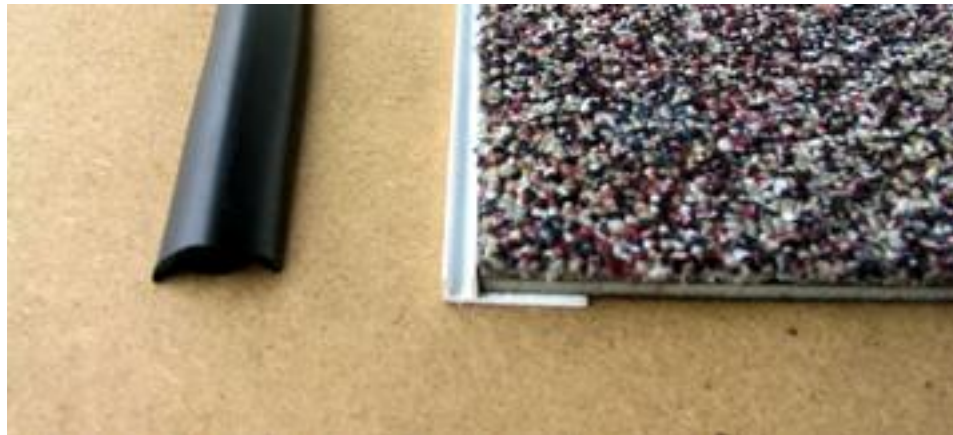

Picture 8-14

Transition Molding completed

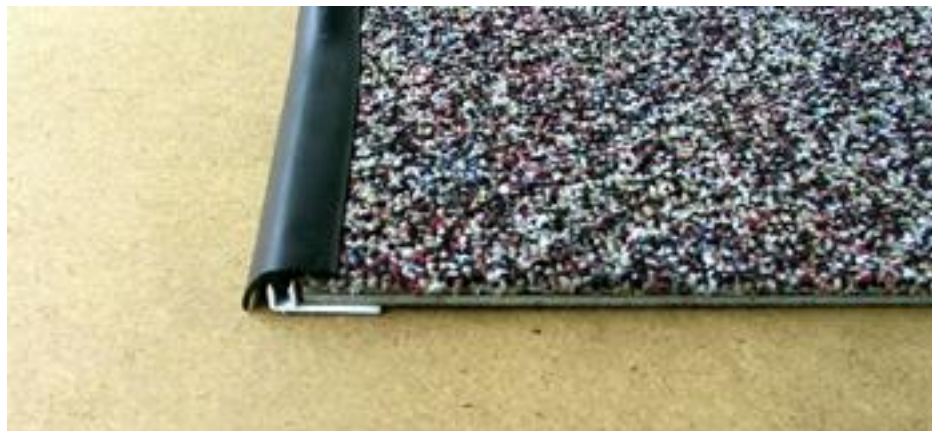

Picture 8-15

Installed Transition Molding



Picture 8-16

Installed Transition Molding



Picture 8-17

Completed Ramp / Rail Access

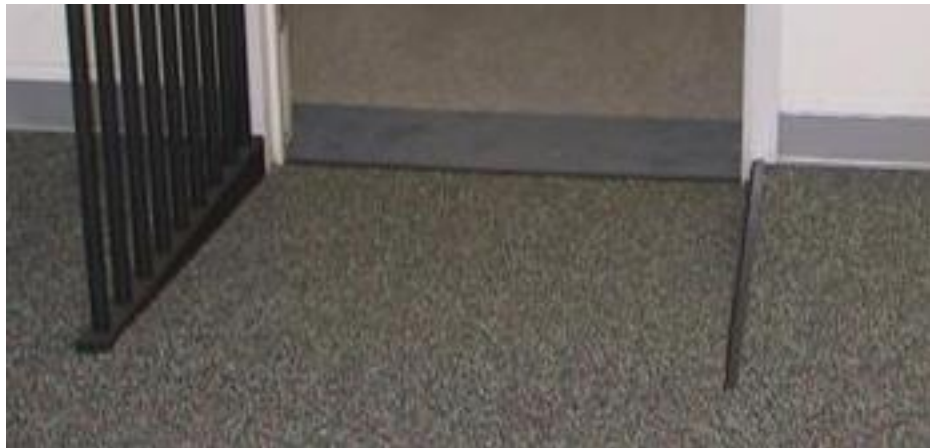

INSTALLING ELECTRICAL SYSTEM

- 1) The drawing will provide all the information necessary to install the electrical power system. (see Detail Plan E)
- 2) A licensed electrician should connect the power input cable assemblies, to the building power, as early in the installation as possible. This will allow for testing of the electrical system, prior to leaving the installation site. The input cable assembly should be connected, to allow a minimum of two feet of cable into the room, this to provide an easy connection of the double ended cable assemblies. Electrical connection to building power source is shown on drawing (see Detail E-1)

Please Note ! In many cases, the Power Input Cable assemblies are provided to the client in advance of the project shipment, so that they can be installed prior to the Powerflor installation. If this is the case, these items will not be part of the shipment you received.

- 3) Each power system leg will begin at the power input cable (Detail E-2) (see Picture 9-1) and will be connected directly to a double-ended eight-wire cable assembly (see Pictures 9-2 & 9-3) The cable length and location will be taken from the drawing. (see Detail E-3)
- 4) The double-ended cable assemblies will be connected to each other, end to end, using a junction block (see Picture 9-4). The junction block may also act as the mounting for a duplex outlet insert.

Please Note ! In some cases, a junction block is used as a cable assembly connector only, providing for the overall length of two cable assemblies, to reach a point. In these cases, no duplex insert is used and no mounting of the junction block into a powerport is done. The junction block simply lays under floor.

- 5) The duplex outlet insert number is located on the drawing (see Detail E 3) and on the insert itself. (see Picture 9-5) The duplex insert will be plugged into the eight-wire junction block. (see Picture 9-6) After the ground, neutral, and hot prongs of the duplex inserts are aligned with the proper holes in the junction block, press the insert down until it is securely attached to the junction block.
- 6) After the junction block and duplex insert are assembled, the outlet will be inserted into the bottom of a powerport. (see Picture 9-7) The drawing will determine the powerport placement.
- 7) After the outlet is snapped into the powerport, it will be held in place with a minimum of two powerport clips. (see Picture 9-8) Place the short end of the clip through one slot in the powerport bottom and the long end of the clip over the bottom of the junction block. Place the second clip on the opposite side and on the opposite end of the junction block in the same manner. (see Pictures 9-9 & 9-10)

- 8) One end of the double-ended cable assembly that powers the leg, will plug into the Junction Block. Make sure the male end of the key way on the cable is aligned with the female end of the junction block (see Picture 9-11) and press together until the locking clip on the junction block is securely latched. (see Picture 9-12)
- 9) Any of the four cable assembly plug locations on the ends of the junction block can be used and all junction blocks are connected to one another in a leg, as per the drawing.

Please Note ! The power layout may call for a junction block to have a cable assembly from the power source, connected to it, with more than one cable assembly connecting additional junction blocks. In this case extra care must be taken to assure that two power legs are not connected to each other in the system.

- 10) Each leg will be color coded with a different color, on location with colored tape. Apply tape at the end of the power input cable and on both ends of every double-ended cable. This should help prevent cross feeding the legs, when the customer relocates the outlets. (see Pictures 9-13, 9-14, & 9-15)
- 11) Once all electrical components are color coded, they can be assembled and mounted to the appropriate floor panels, progressing out each electrical leg. The floor panels are relocated back into the floor, locating the cable assemblies between the panel legs. (see Pictures 9-16 & 9-17)
- 12) If at all possible, test all electrical after installation and before leaving the installation site. This is usually accomplished by turning on the circuit feeds at the breaker and testing each circuit with an electrical tester or by simply operating an electrical tool from each outlet.

Detail Plan E

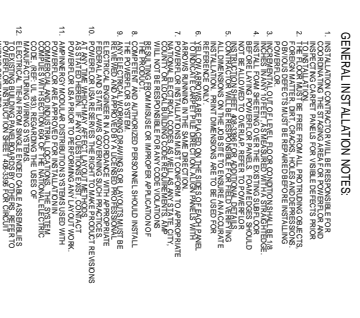
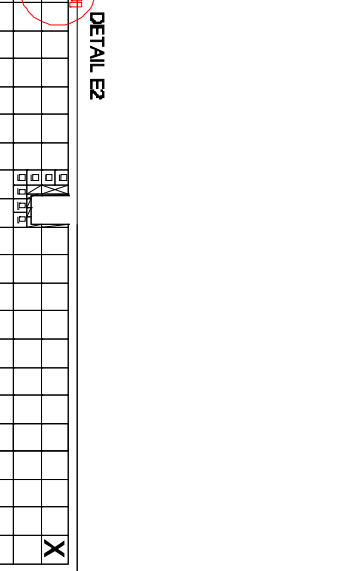
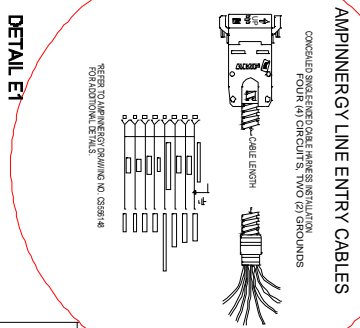
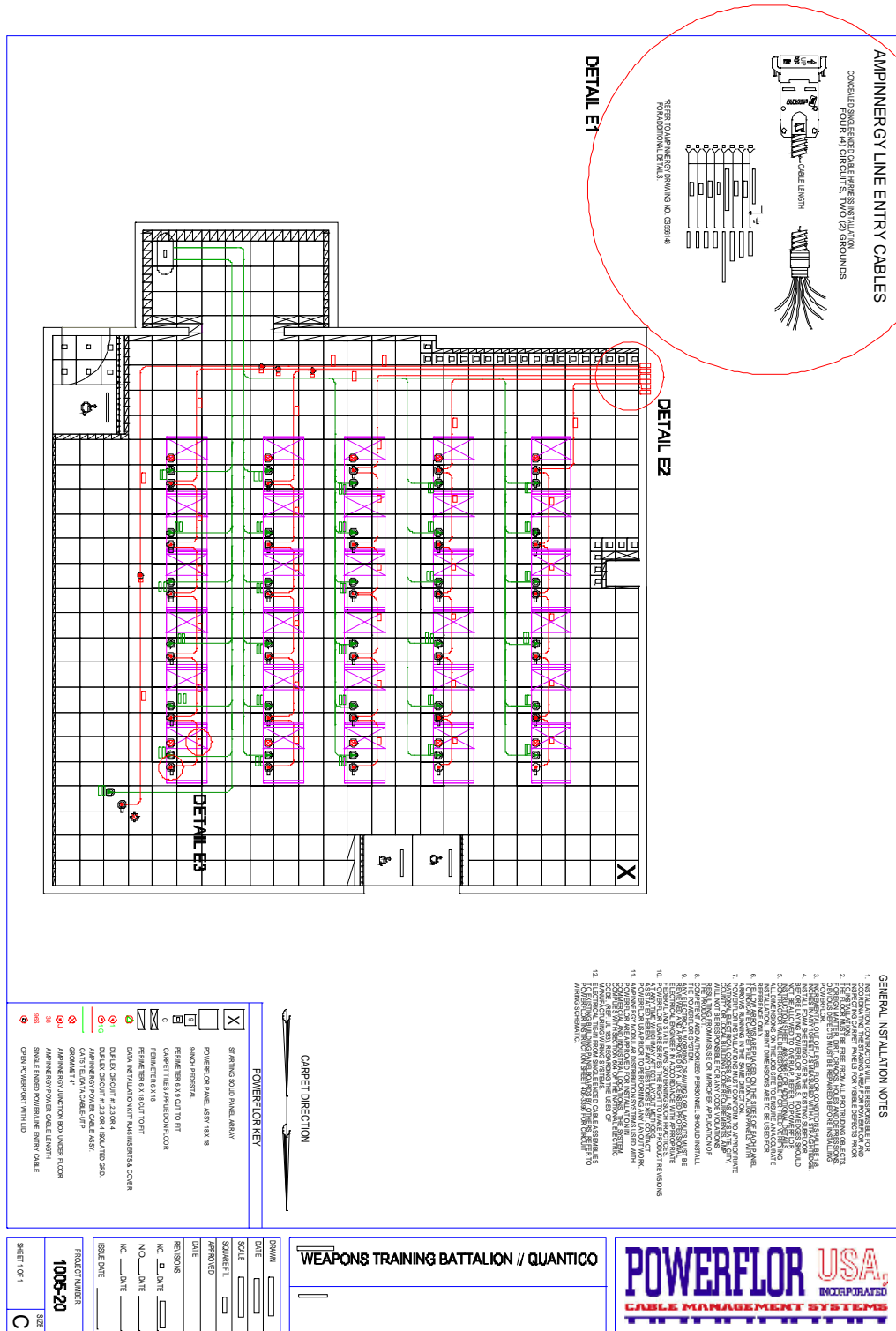

- #### GENERAL INSTALLATION NOTES
1. INSTALLATION CONTRACTOR WILL BE RESPONSIBLE FOR PROTECTING EXISTING UTILITIES AND STRUCTURES FROM DAMAGE DURING THE CONSTRUCTION OF THIS PROJECT.
 2. ALL WORK SHALL BE IN ACCORDANCE WITH THE LATEST EDITIONS OF THE NATIONAL ELECTRICAL CODE (NEC) AND ALL APPLICABLE LOCAL, STATE AND FEDERAL REGULATIONS.
 3. THE CONTRACTOR SHALL BE RESPONSIBLE FOR OBTAINING ALL NECESSARY PERMITS AND APPROVALS FROM THE APPROPRIATE AGENCIES.
 4. ALL WORK SHALL BE COMPLETED WITHIN THE SPECIFIED TIME FRAME AND TO THE SATISFACTION OF THE PROJECT MANAGER.
 5. THE CONTRACTOR SHALL MAINTAIN CLEAR ACCESS TO ALL EXISTING UTILITIES AND STRUCTURES AT ALL TIMES.
 6. ALL WORK SHALL BE COMPLETED IN ACCORDANCE WITH THE PROJECT SCHEDULE AND BUDGET.
 7. THE CONTRACTOR SHALL BE RESPONSIBLE FOR THE PROTECTION AND MAINTENANCE OF ALL EXISTING UTILITIES AND STRUCTURES.
 8. ALL WORK SHALL BE COMPLETED IN ACCORDANCE WITH THE PROJECT SCHEDULE AND BUDGET.
 9. THE CONTRACTOR SHALL BE RESPONSIBLE FOR THE PROTECTION AND MAINTENANCE OF ALL EXISTING UTILITIES AND STRUCTURES.
 10. ALL WORK SHALL BE COMPLETED IN ACCORDANCE WITH THE PROJECT SCHEDULE AND BUDGET.
 11. THE CONTRACTOR SHALL BE RESPONSIBLE FOR THE PROTECTION AND MAINTENANCE OF ALL EXISTING UTILITIES AND STRUCTURES.
 12. ALL WORK SHALL BE COMPLETED IN ACCORDANCE WITH THE PROJECT SCHEDULE AND BUDGET.

POWERFOR KEY

X	STARTING SOLID PANEL ARRAY
1	POWERFOR PANEL ASST 18X 9
2	480V FEEDS/CL
3	RESISTER & X1 OUT TO TR
4	CABLE TRAY SANDDOWN FLOOR
5	FRAMERS & X1 OUT TO TR
6	DATA INSTALLATION/ RAINBOWS & COVER
7	DATA EX CIRCUIT IN 230V 4
8	DATA EX CIRCUIT IN 230V 4/QUANTITY QND
9	AMPINNERGY POWER CABLE ASST
10	AMPINNERGY POWER CABLE ASST
11	AMPINNERGY JUNCTION BOX UNDER FLOOR
12	AMPINNERGY POWER CABLE LENGTH
13	SCALE ENDED POWER/VALUE ENTRY CABLE
14	OPEN OVERPOINT WITH LD

DRAWN	DATE
SCALE	SCALE
ISSUED	ISSUED
REVISIONS	NO. DATE
NO.	DATE
NO.	DATE
ISSUE DATE	

WEAPONS & TRAINING BATTALION // QUANTICO



AMPINNERGY LINE ENTRY CABLES

CONCEALED SINGLE-ENDED CABLE HARNESS INSTALLATION
FOUR (4) CIRCUITS, TWO (2) GROUNDS

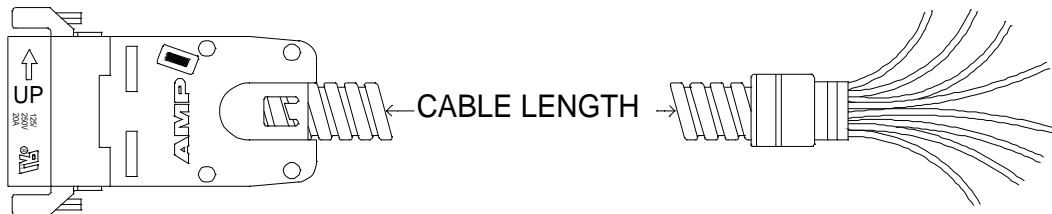

1	GREEN/BARE	GROUND
2	WHITE	NEUTRAL
3	GRAY	NEUTRAL 4
4	GREEN/YELLOW	ISOLATED GROUND
5	PINK	LINE 4
6	BLACK	LINE 1
7	RED	LINE 2
8	BLUE	LINE 3

Detail E-2

Drawing Detail Power Input Cable assembly

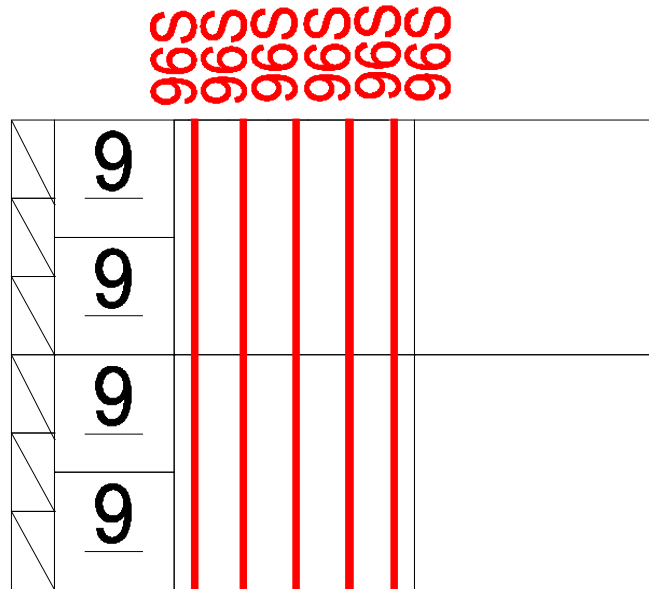

Detail E-3

Drawing Detail Cable Assm. & Outlet

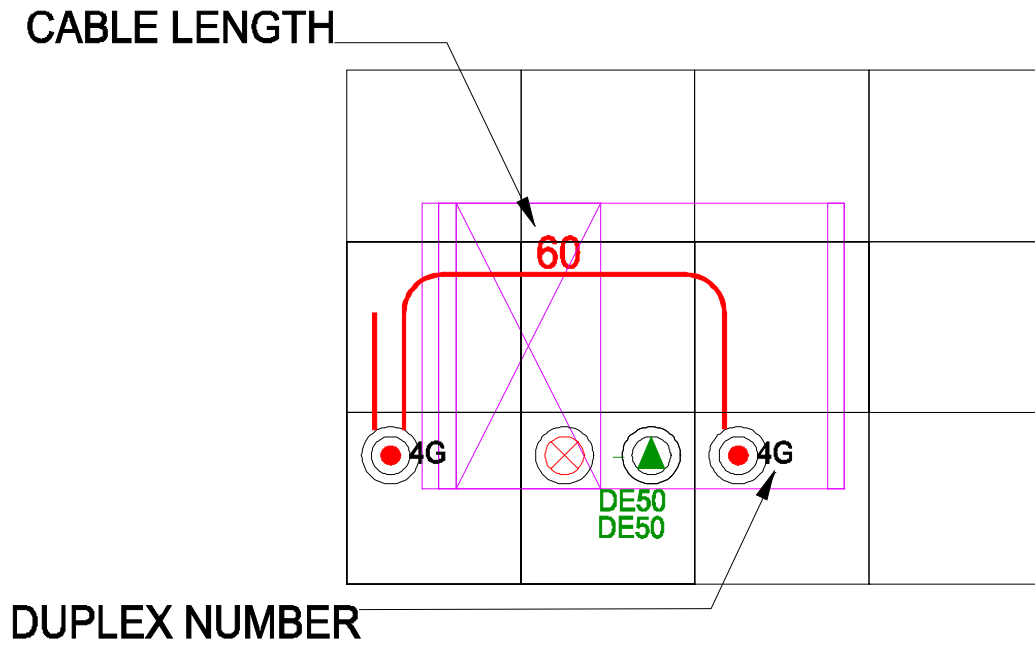

Picture 9-1

Single Ended Power Input Cable Assembly



Picture 9-2

Double Ended Cable Assembly



Picture 9-3

Power Input and Double Ended Cable connected



Picture 9-4 Double Ended Cable Assembly connected with a Junction Block



Picture 9-5 Duplex Outlet with Circuit Number



Picture 9-6 Installing Duplex Outlet Insert in Junction Block

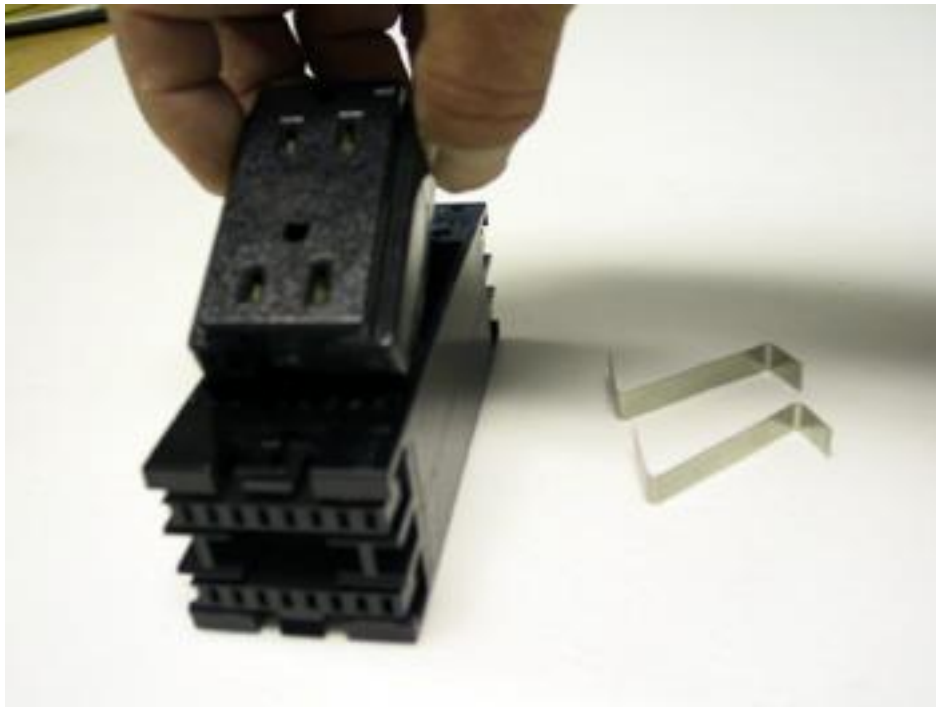

Picture 9-7 **Installing Junction Block into Powerport**



Picture 9-8 **Installing Powerport Clips**



Picture 9-9

**Completely Installed Electrical Outlet
(Bottom View)**

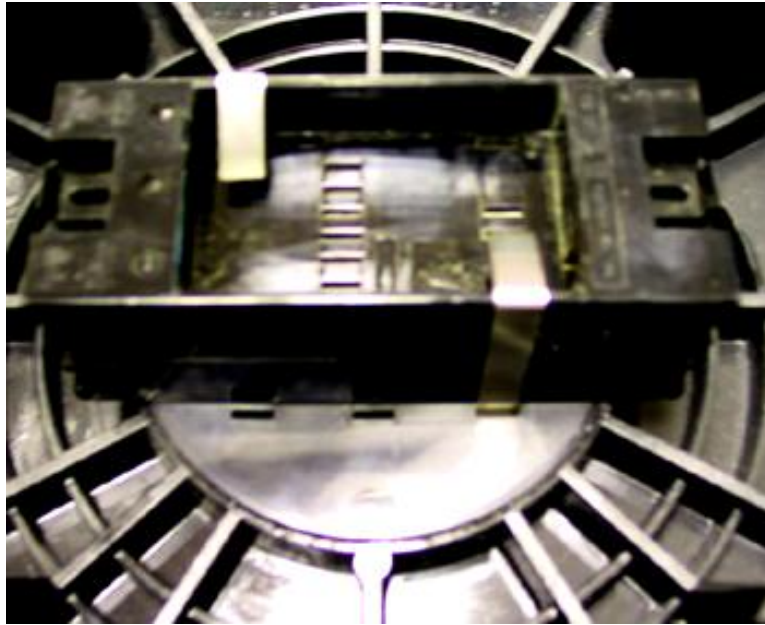

Picture 9-10

**Completely Installed Electrical Outlet
(Top View)**



Picture 9-11 **Installing Double Ended Cable to Junction Block**
(Note keyway alignment)

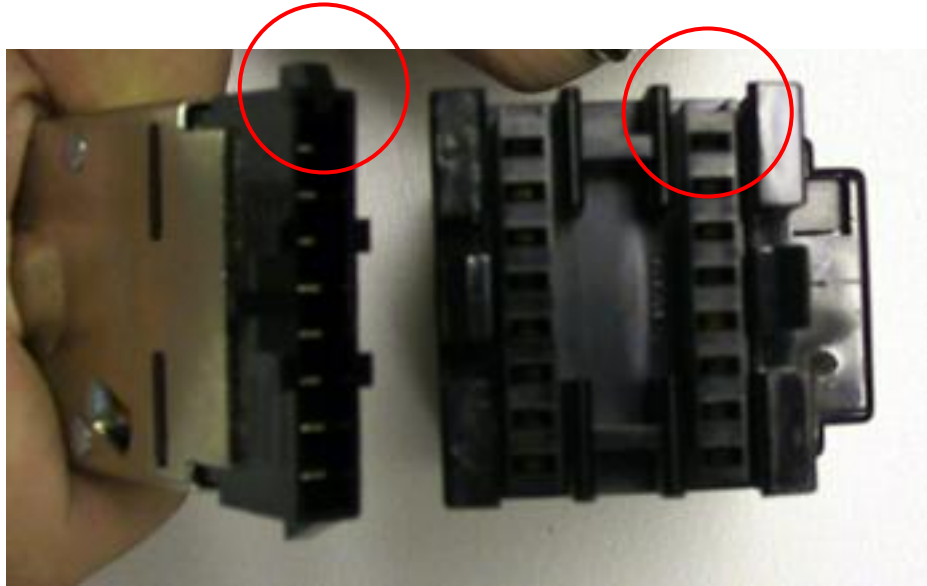

Picture 9-12 **Installed Cable Assembly to Junction Block**

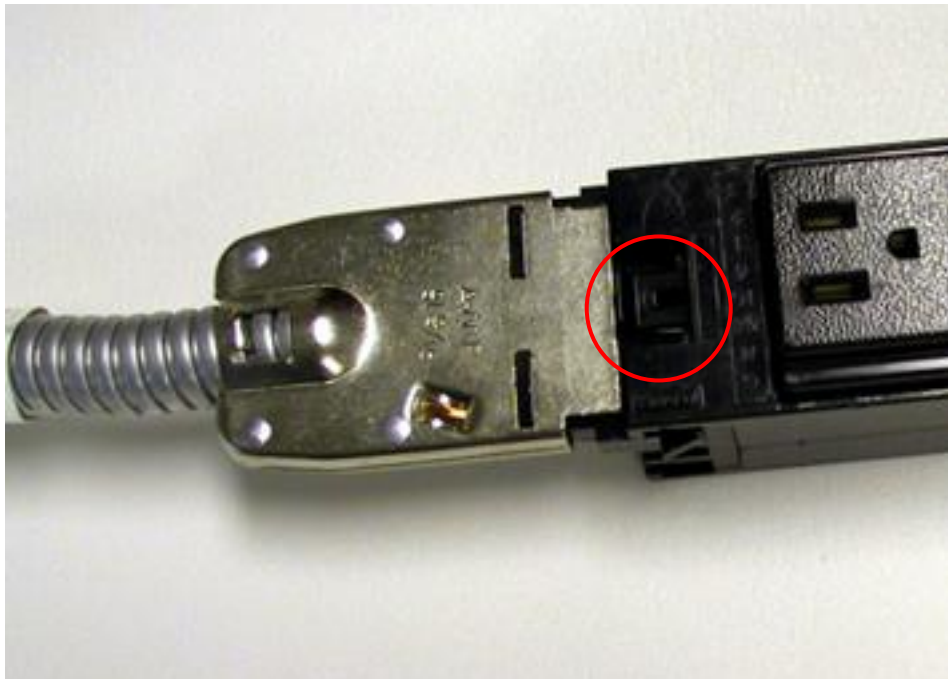

**Picture 9-13
Colored Electrical Tape**



**Picture 9-14
Applying Color Coding**



**Picture 9-15
Completed Color Coding of Cable Assembly**



Picture 9-16 **Completed Panel with Cable Assembly connected**



Picture 9-17 **Installing completed panel into system**



INSTALLING DATA/COMMUNICATIONS SYSTEM

- 1) The drawing will provide all the information necessary to install the Data Communication system. (see Detail Plan DC)
- 2) The drawing will determine the location of all data ports and the pre-terminated data cable length. (See Detail DC-1) For example the DE75 indicates a pre-terminated data cable, 75 feet long.
- 3) After determining the proper length data cable to be run from the Data / Comm outlet to the service point, un-package and number the data cable on both ends. (see Pictures 10-1 & 10-2)

Please Note ! The service point for the Data / Comm system may be a Powerflor LDS Utility Center or can be a client provided wiring closet. In either case determine the proper amount of cable length to be exposed for connection to the service point.

- 4) If an LDS Utility Center is to be used, the drawing will determine the location of the LDS. (see Detail DC-2)
- 5) The LDS Utility Center is provided as a cabinet, a base unit, and assembly hardware. (see Picture 10-3) The base shall be located into the Powerflor system, replacing one full panel. (see Pictures 10-4 & 10-5) The cabinet will require attachment to the base with 4 bolts and its assembly is self explanatory. (see Picture 10-6) Any patch panels, if provided by Powerflor, shall be located on the mounting track per user preference. (see Pictures 10-7 & 10-8)
- 6) The data cables leaving the LDS or the wiring closet will be velcro tie wrapped at least every three feet to present a neat appearance. (see Pictures 10-9 & 10-10) They will also be wrapped each time a cable or cables split off to a data outlet. (see Picture 10-11) All cabling will be laid / rolled out to prevent its becoming damaged or tangled. The remainder of excess data cable length will be neatly rolled and velcro tie wrapped at the data outlet to prevent the excess cable from becoming tangled or damaged in the future and to allow for future relocation of the outlet. (see Picture 10-12)

Please Note ! Data cables will not be pulled as a practice (only in a must do situation).All cables should be uncoiled (rolled out) and placed on the sub-floor and panels placed over them. Care must be taken to assure that the panel legs are not placed on top of the cable.

- 7) Once the LDS is installed, all data cables will be fed from under the floor through the LDS base and up into the LDS cabinet, (see Picture 10-13) using the voids in the sides as a vertical chase.

- 8) All data cables will be plugged into the patch panels mounted in the LDS Utility Center and neatly numbered. (see Picture 10-14)

Please Note ! If project calls for a client provided wiring closet, the Powerflor installation stops at the placement of the data cables in the wiring closet location

- 9) The LDS Utility Center when completed (see Picture 10-15) shall be made available to the client or his communication contractor for connection to services from the building. Once this work is done, the doors for the Utility Center shall be set in place and locked (see Picture 10-16) with the keys, delivered to the appropriate party.
- 10) Some projects may be designed and specified for the client to provide Data / Comm electronics to be installed in the Utility Center. In these instances the Utility Center will not have any patch panels in it. If it is required Powerflor will provide a “ Bubble Back “ unit, to allow for the dimensional depth of the electronics. (see Picture 10-17) This unit is used as a replacement for one of the doors on the LDS Utility Center.

Detail DC-1

Drawing Detail Data / Comm Outlet & Cable

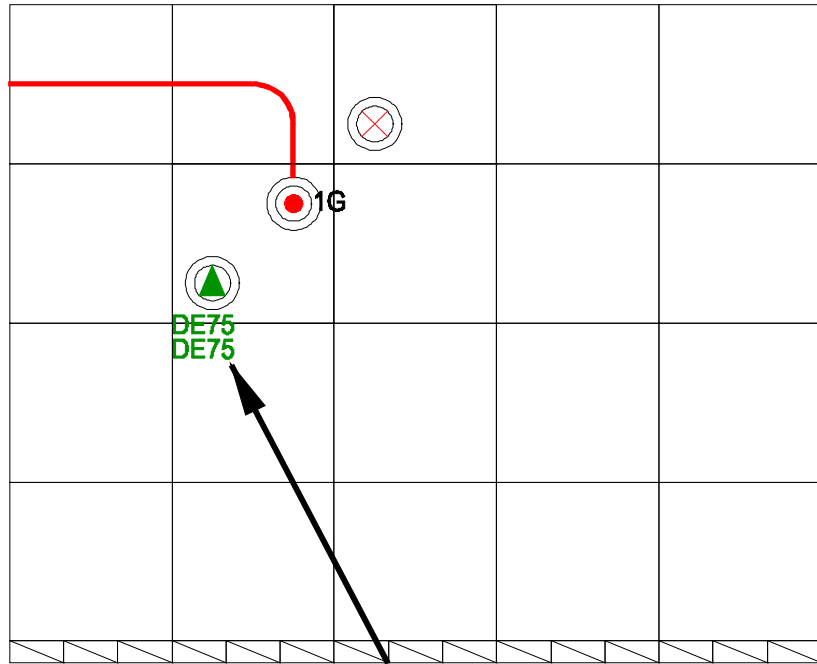

Detail DC-2

Drawing Detail - LDS

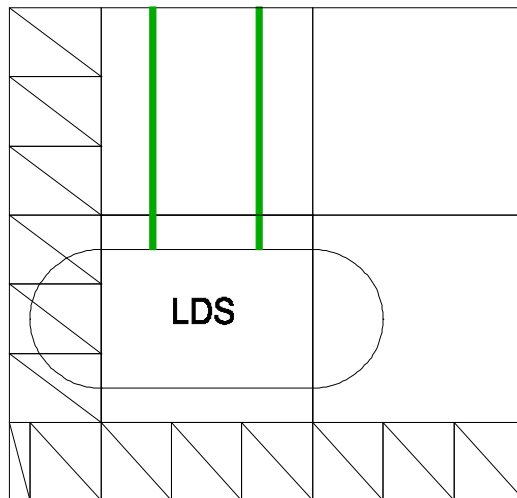

Picture 10-1 **Packaged Data Cables as provided**



Picture 10-2 **Pre-Terminated Data Cables with numbering**

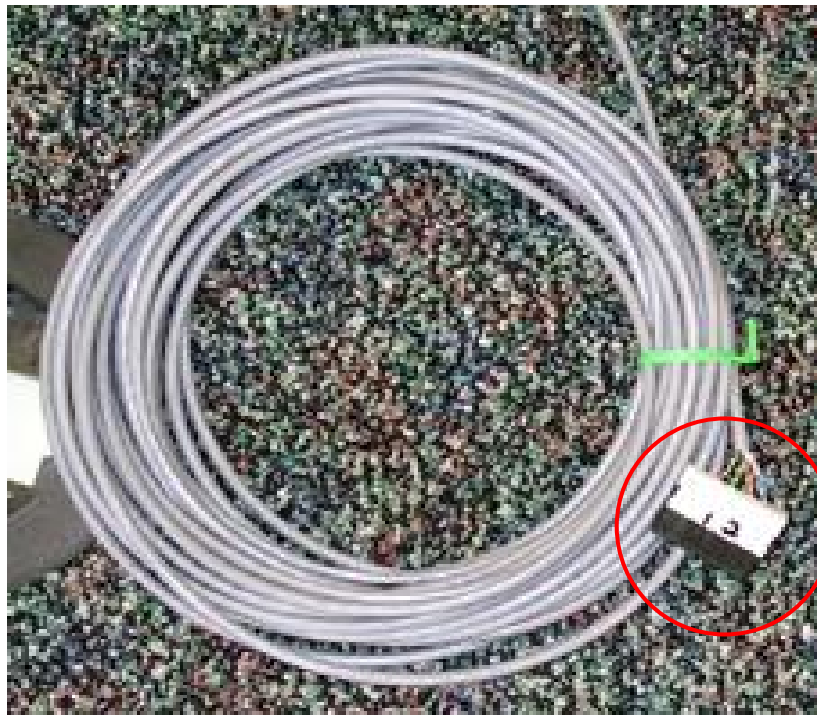

Picture 10-3

LDS Cabinet, Base, and Hardware as provided



Picture 10-4 **18" x 18" x 3" LDS Base Unit**



Picture 10-5 **LDS Base Unit located in floor system**



Picture 10-6

Installing LDS Cabinet to Base Unit



Picture 10-7

Typical LDS Patch Panels



Picture 10-8

LDS - 19" Wire Rack Mounting Bracket

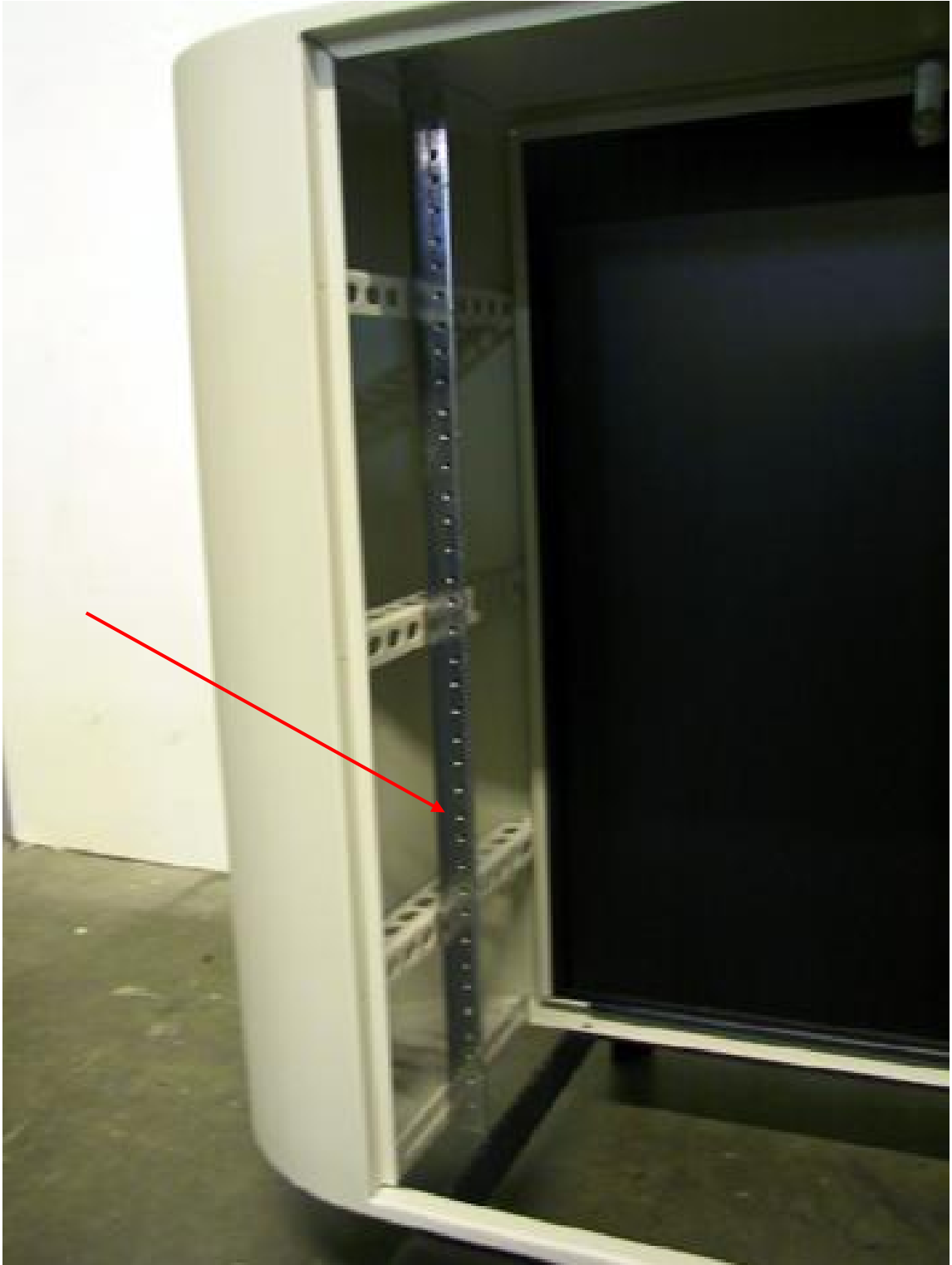

Picture 10-9 Pre-Terminated Data Cables at LDS



Picture 10-10 Installing Data Cables



Picture 10-11

Data Cables properly tie-wrapped



Picture 10-12

Installing Data Cables



Picture 10-13

LDS with Data Cables fed through



Picture 10-14 **Connecting Data Cables to Patch Panel in LDS Cabinet**



Picture 10-15 LDS with Patch Panels and Data Cables



Picture 10-16 LDS Center completely installed



Picture 10-17

Optional LDS Bubble Back



DATA / COMM OUTLET INSTALLATION

To complete the Data / Comm system, the outlets must be assembled and connected. The standard Powerflor system uses a Data / Comm outlet housing kit with insert-able connection jacks. This is a tyco / AMP product, called an ACO outlet.

- 1) The ACO housing part of the kit will be prepared for use by breaking off the square ends and removing the retaining screws. (see Pictures 10-18, 10-19, & 10-20) Also, from the back of the kit, remove the mod-edge connector card using a small phillips-head screw driver (see Pictures 10-21 & 10-22) These parts can be discarded.
- 2) After feeding the mod-edge connector end of the pre-terminated cable through the powerport, the card edge connector provided on the pre-terminated data cable will be attached to the rear of the ACO kit, using a small Phillips-head screwdriver. (see Pictures 10-23, 10-24, & 10-25)
- 3) Place the ACO kit into the powerport and press until fully seated. (see Pictures 10-26, 10-27, & 10-28)
- 4) Place the appropriate ACO connector insert (typically RJ-45) into the kit engaging the card edge connector attached to the pre-terminated cable. (see Pictures 10-29 & 10-30) Number insert appropriately.

If the ACO product does not meet the client's requirements, Powerflor provides a Data Adaptor Plate. This adaptor plate allows for the installation of a wide selection of alternative data outlet device faceplates.

- 1) When using an alternative faceplate for mounting the Data / Comm. outlet connectors, you will be required to install a data adaptor plate into the powerport. (see Picture 10-31) The data adaptor plate will only fit into the powerport one way. The adaptor plate will be attached to the powerport with two screws through the pilot holes in the bottom of the powerport. (see Pictures 10-32 & 10-33)
- 2) Insert the alternative faceplate by sliding the retaining tab onto the edge of the inner rectangular hole in the plate and pressing down until the retaining clip is fastened. (see Picture 10-34) Insert the appropriate connectors into the alternative faceplate and number accordingly.

Please Note ! When an alternative Data / Comm outlet / faceplate is used, parts beyond the data adaptor plate may or may not be a Powerflor provided part. And pre-terminated Data / Comm cables may or may not be provided. In all cases, your work as an authorized installer for Powerflor will be limited to only and all parts of the system, provided by Powerflor.

If installing alternative faceplates and connectors is part of the Powerflor installation, it may be more time effective to install these items in the Powerflor Data Adaptor Plate, prior to installing it into the powerport.

Picture 10-18

ACO Outlet Housing Kit as provided



Picture 10-19

ACO Kit with tabs and screws removed

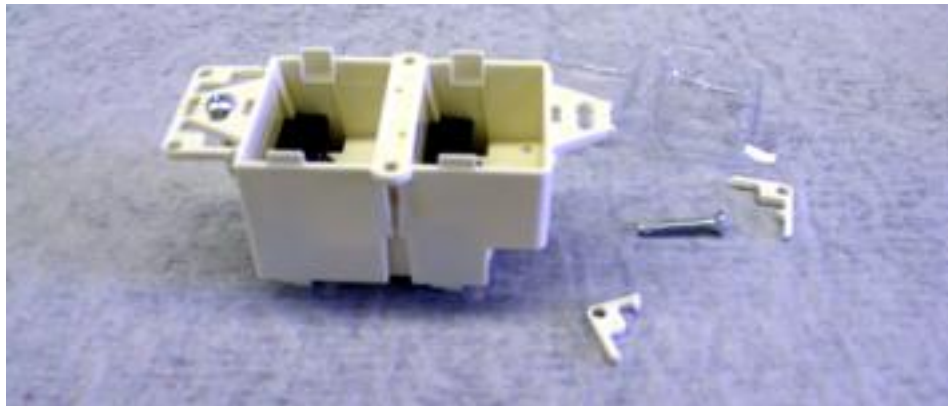

Picture 10-20

ACO Kit with tabs and screws removed

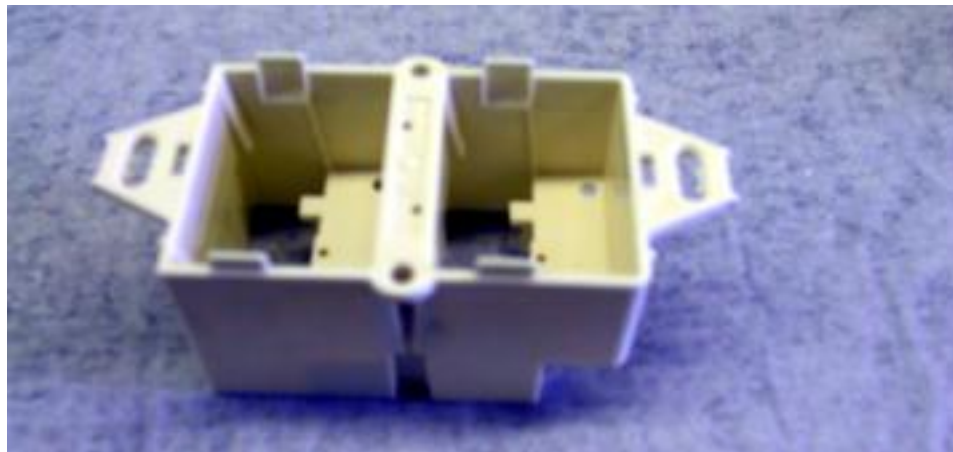

Picture 10-21

ACO Kit with Mod-Edge connectors

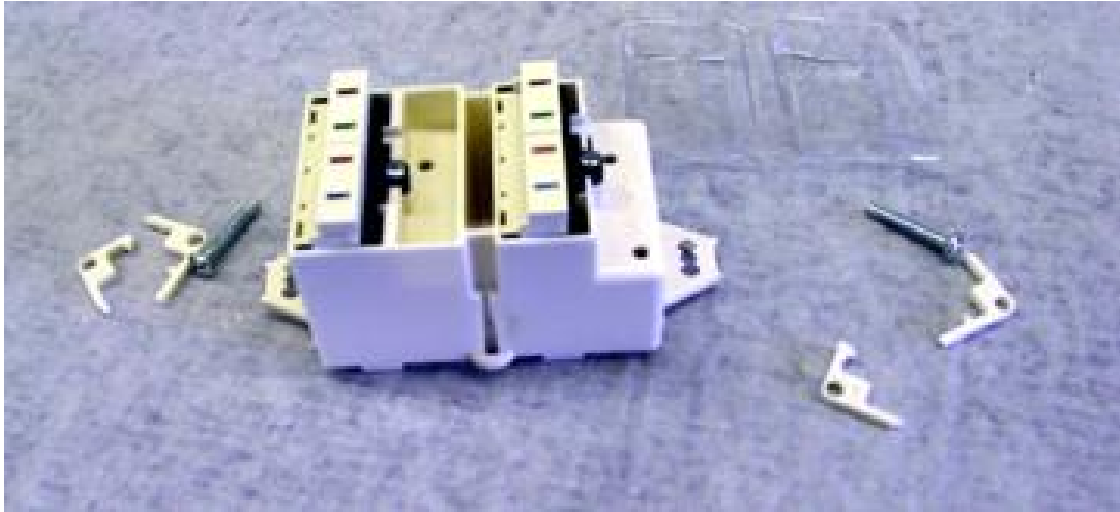

Picture 10-22

ACO Kit with Mod-Edge connectors removed

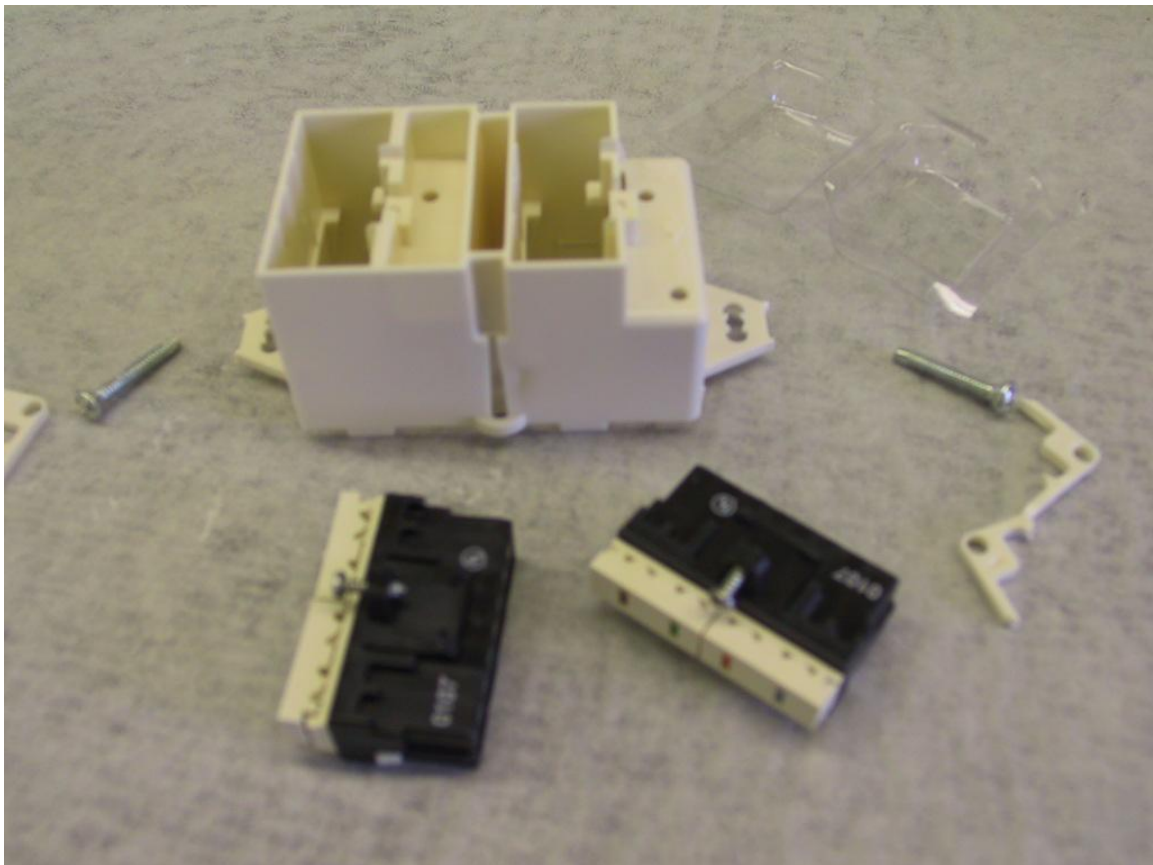

Picture 10-23 Mod-Edge end of Data Cable through Powerport



Picture 10-24 Installing Data Cable to ACO Kit



Picture 10-25 Pre-Terminated Data Cable connected to ACO Kit

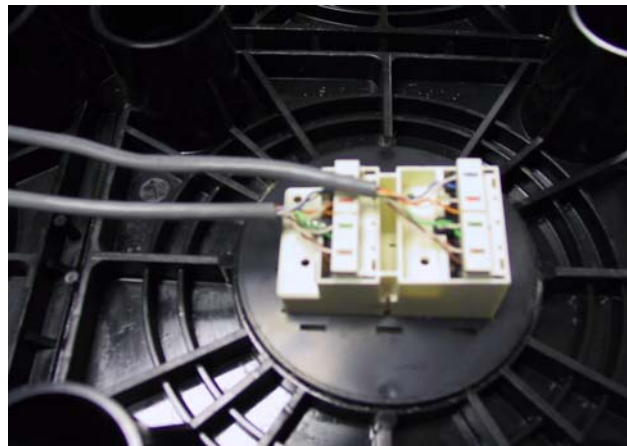

Picture 10-26 Installing ACO Kit into Powerport



**Picture 10-27
Installing ACO Kit into Powerport**



**Picture 10-28
ACO Kit installed in Powerport**

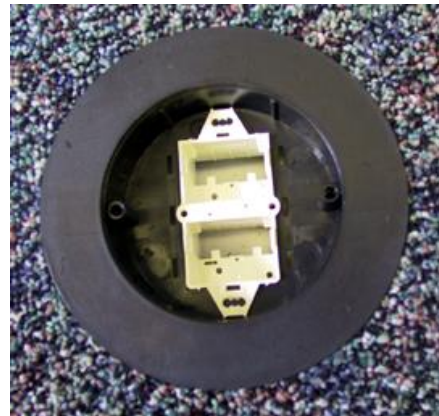

Picture 10-29

Installing ACO connectors into Kit



Picture 10-30

Completed ACO Data Outlet

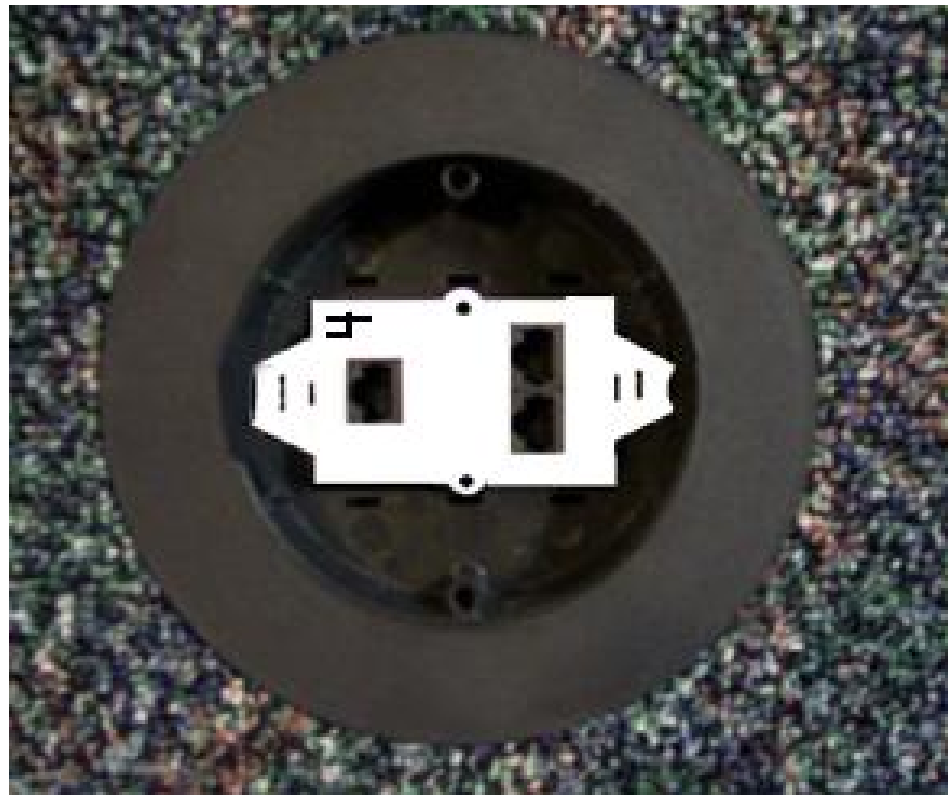

Picture 10-31 Data Adaptor Plate and mounting screws



Picture 10-32 Data Adaptor Plate & Powerport with locating pilot holes

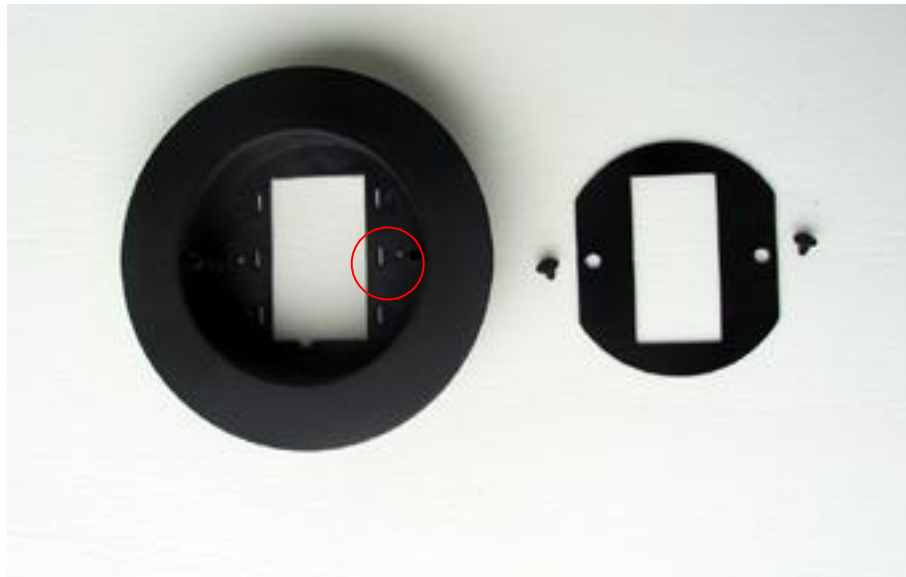

Picture 10-33 Completed Adaptor Plate Outlet

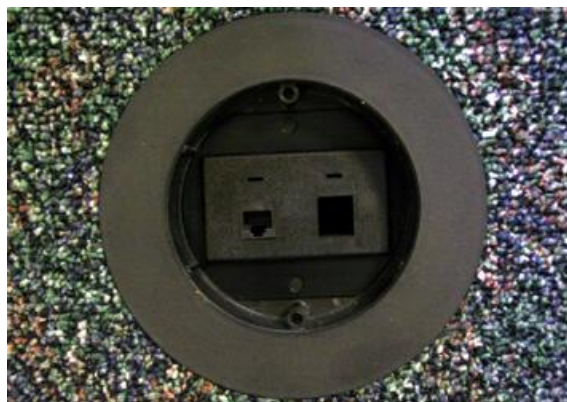

Picture 10-34 **Data Adaptor Plate with alternative faceplate and connectors installed**

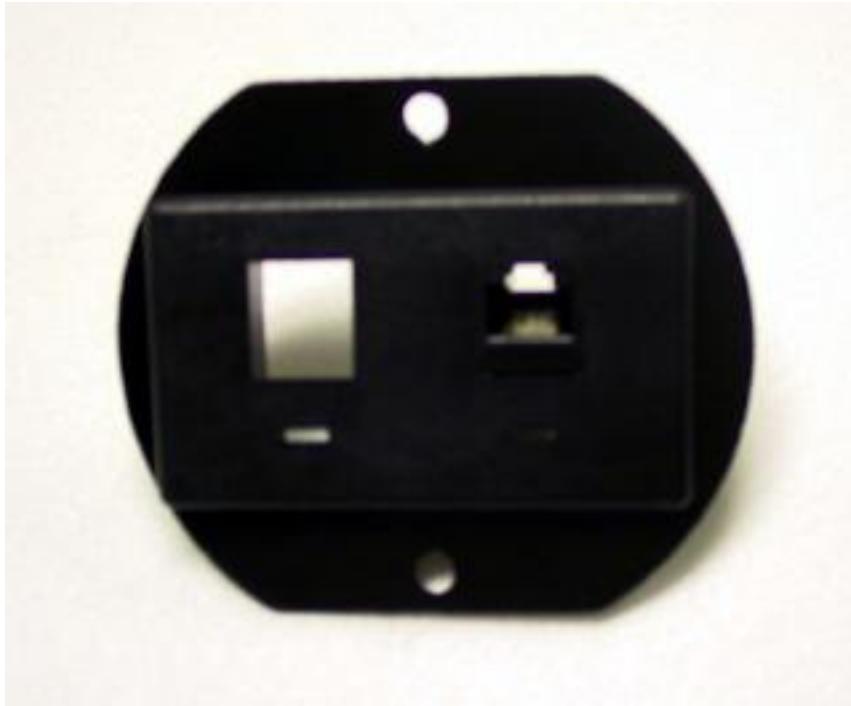

COMPLETING THE PROJECT

- 1) One of the final steps is the powerport lid placement. The standard powerport lid is a black metal lid with two flip doors to allow access to the outlet. (see Picture 11-1) The lids have two digit posts for alignment with and into alignment holes in the powerport. These lids should be placed in such a manner to allow the flip doors to open in the same direction depending on the direction of the power port (i.e. all lids that open left or right should be in the same direction).
- 2) Powerflor also offers and your project may include several flat powerport lids, with and without cable holes through the lid. These lids are installed in the same manner as described for the standard lid, without any directional concerns. (see Picture 11-2)
- 3) Additionally, Powerflor offers a Domed Tamper-Proof lid. This lid must be attached with the two screws provided, using the powerport alignment holes as your screw location.
(see Picture 11-3)

As a final completion step, all debris should be removed and the floor vacuumed to leave an attractive and clean installation. All shipping materials removed from the jobsite, and all extra parts provided to the client.
(see Picture 11-4)

Picture 11-1

Standard Powerport Lid



Picture 11-2

Powerport Flat Lid

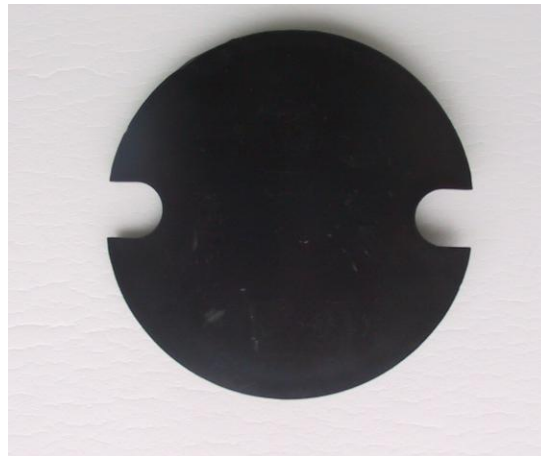

Picture 11-3

Powerport Tamper-Proof Dome Lid



Picture 11-4

Completed Room



RECESSED FLOORS

Recessed floors are becoming a common option / practice with new construction. This type of installation provides the Powerflor system without the need for any ramps or railings. The desire, is to have a floor surface where the Powerflor system is not identifiable. Recessed type installations can be confined to a room or in the middle of an open area.

The sub-floor will be provided, recessed 2 5/8 inches to accommodate the Powerflor system in all areas where the system is to be installed. Although the entire surface is important, the edges of the recess area are critical to produce an even transition in and out of the system area. (see Detail 12-1)

If the floor recess is more or less than 2 5/8 inches, at the edge area and horizontally into the recess 30", it must be chipped / ground out or built up / shimmed to produce the exact height and provide a smooth transition line.

Please Note ! The client and their contractors have been made aware of the importance of the dimensional integrity of the recessed areas. It is their responsibility to provide all recessed areas, with the correct recess. This can be easily checked by taking one of our perimeters or loose pedestals and sliding it around the edge, checking to make sure that the top of our un-carpeted parts are even with the raised sub-floor. If there are areas of concern, and they are of a minor nature, we recommend that they be taken care of as part of the installation. If there are major problem areas, do not begin the installation. Contact your Powerflor sales representative.

Installing the floor components in this type of installation is the same as a standard installation. Installing the carpet tiles on the perimeter pieces, may be different, if the recess is not consistent with a room's walls.

If the recess area's edge is not located where there is a wall or other fixed border the carpet tiles will lap over onto the sub-floor area, that is even with the top of the Powerflor support structure. In cases where the recess is located in the middle of an open area the carpet tile will lap over all edges. In cases where the recessed area is consistent with a room, the carpet tiles will lap over to the raised sub-floor at door / access thresholds only. (see Pictures 12-1, 12-2, 12-3 & 12-4)

Please Note ! There are two important points to this type of installation.

One, whenever possible, the location of a carpet tile seam should not be at the edge of the recessed area, unless at a wall. Carpet tile should lap over the edge, from the system to the raised sub-floor.

Two, carpeting of the remainder of the areas around the system, should be done after the Powerflor system installation is complete, to insure a factory carpet tile edge to a factory carpet tile edge installation of the carpet tiles.

All other installation procedures for installing the floor remain the same.

Detail 12-1

Drawing Detail of Recessed Floor Slab

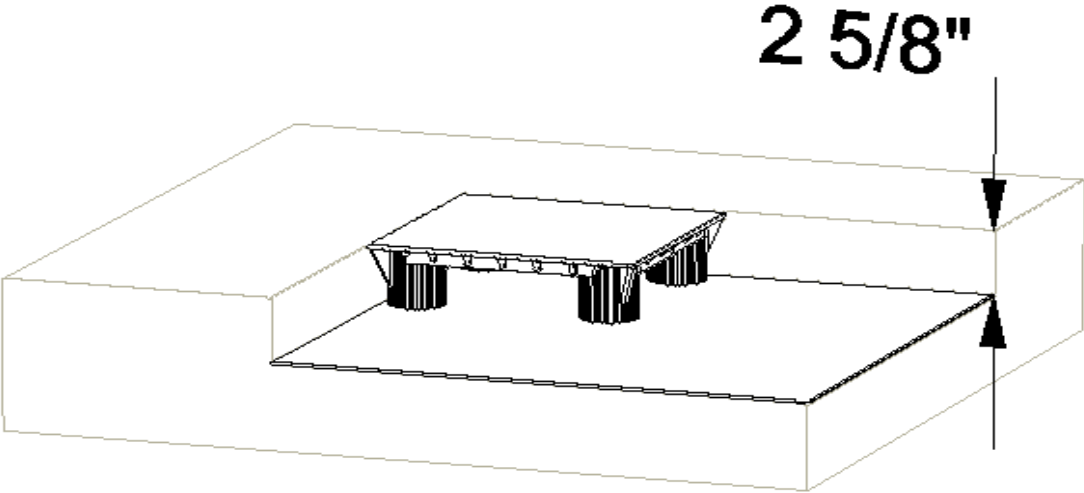
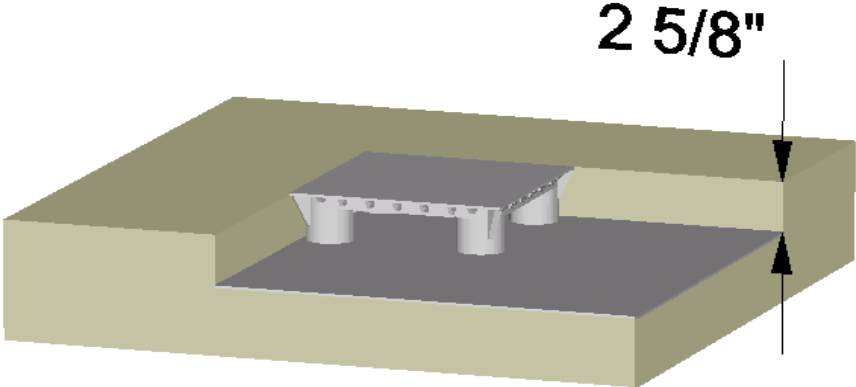

Picture 12-1

**Recessed Sub-floor at Door Opening with
Foam Underlay**



Picture 12-2

**Recessed Sub-floor with full panels requiring
perimeter filler**



Picture 12-3

Recessed Sub-floor with full panels and perimeter filler installed



Picture 12-4

Recessed Sub-floor at Door Opening with full carpet tile overlaying perimeter and sub-floor seam



REPLACING CARPET TILE

The Powerflor system is standardly provided using cushion-backed carpet tiles, adhered with pressure sensitive adhesive. This adhesive is designed to release, when gravity is no longer in effect and re-adhere when the surfaces are re-attached. Use of the cushion-backed carpet tile and this type of adhesive, allows for the replacement of the carpet tile, on a our system. It is highly recommended that when replacing carpet tiles, this same adhesive is used to adhere the replacement tiles. Powerflor will provide pre-glued carpet tiles for carpet tile replacement of its systems. Please consult with our customer service department as to availability and matching capabilities.

Please Note !!! The Powerflor system may also be provided using customer specified / provided carpet tiles that are hard-backed. Because of the PVC content of this type of carpet tile backing, they are adhered using a permanent adhesive. Replacement of the carpet tile when this type of carpet and adhesive is used, cannot be accomplished and requires the replacement of the chaseway floor componentry.

The requirement for replacement of carpet tiles can occur as a result of two types of circumstances. First, a small area or multiple tiles throughout a project, as a result of staining or damage. Second, when the carpet wears out and needs to be replaced on the entire system. The process to accomplish both types of replacement is basically the same, although when doing a large square footage of Powerflor, the set up is quite different to accommodate the quantity of panels you will be dealing with. Site conditions, access, and quantity of replacements required, are all considerations of which approach is best for the required replacement.

REPLACING CARPET TILE (SMALL AREAS)

- 1) All panels requiring carpet tile replacement need to be removed from the floor system and set on their edge, until pedestals and or perimeters become loose enough to pull off the carpet tile manually. If panels have outlets, remove outlet and powerport from panel.
- 2) Manually pull off all components from existing carpet tile and discard old carpet tile.
- 3) The new “ pre-glued “ carpet tile should be placed on a flat surface, pile side down. Remove wax paper glue protection sheet and discard.
- 4) Place existing componentry onto new carpet tile, and press until adhered. The components are to be placed in same configuration as they were removed to assure proper carpet grain direction indicators and location of cut perimeters, powerports, etc.
- 5) Place new carpeted panel back into the same location in the system, remounting outlets as required.

Caution !!! If area is occupied during this process, appropriately block areas with missing panels to prevent a tripping hazard.

REPLACING CARPET TILE (LARGE AREAS)

To accomplish the carpet tile replacement for a total system or a large area replacement project we have established the following recommended procedures as a guideline to minimize the labor required and to assure the system's layout and function. This method requires the use of specialized tools to allow for the removal of the pedestals with ease, and is most effective with multiple people in an assembly line type, panel-by-panel removal, disassembly, reassembly and replacement procedure.

It is recommended that the carpet tiles be purchased through Powerflor USA Inc, pre-glued and ready for replacement install.

Tools Required

The tools listed with a part number are available to certified installers, for use in carpet replacement projects. The drill press with hole saw and the workbench will be self-supplied by the certified installer.

TOOL	PART NUMBER	QUANTITY
Pedestal Puller (Picture 13 –1)	PF101	2
Panel Holder (Picture 13 –2)	PF201	1
Carpet Holder (Picture 13 –3)	PF202	1
Panel Jig (Picture 13 –4)	PF301	1
Hole Jig (Picture 13 –5)	PF401	1
Drill Press with 4" Hole Saw (Picture 13 –6)	(Locally Purchased)	1
Work Bench (No Photo)	(Locally Purchased)	1

Picture 13 – 1

Pedestal Puller

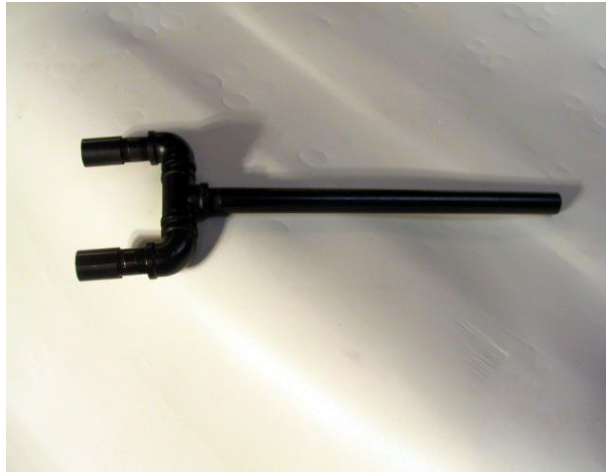

Picture 13 – 2

Panel Holder

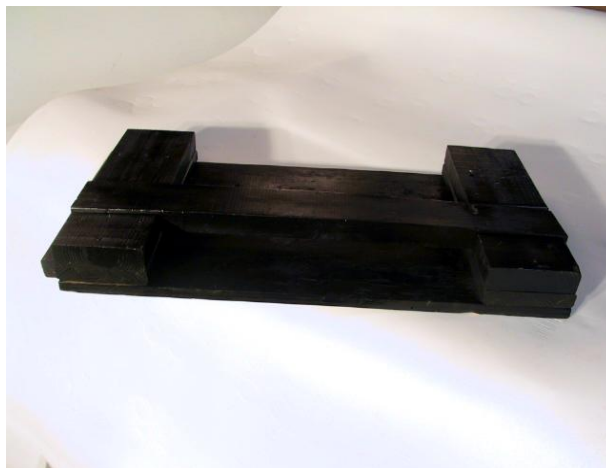

Picture 13 – 3

Carpet Holder

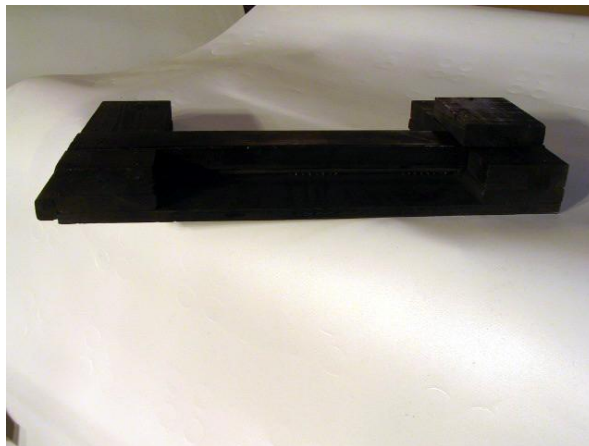

Picture 13 – 4

Panel Jig

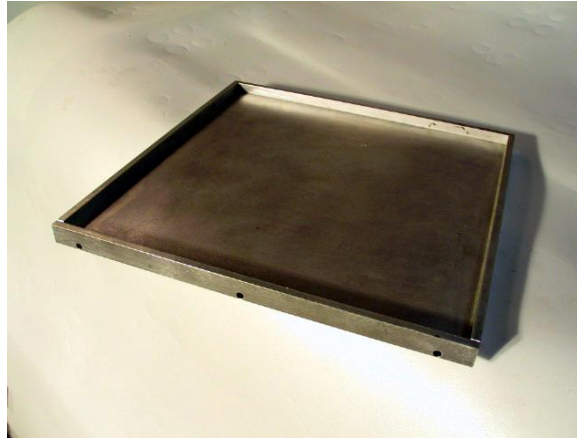

Picture 13 – 5

Hole Jig

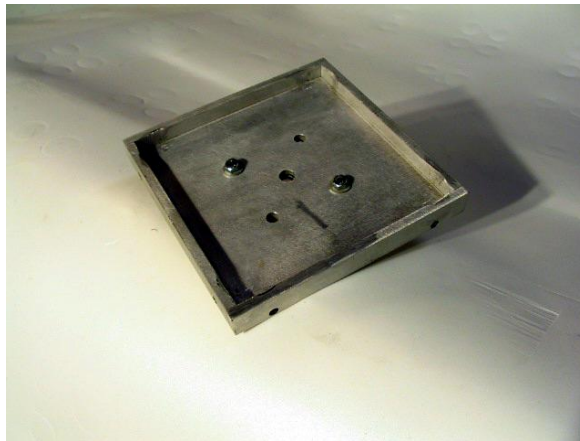

Picture 13 – 6

Drill Press w/ 4" hole saw



Assembly Line Process

Set up bench with tools and work that immediate area. Relocate the bench as the project progresses. Each personnel position should be coordinated with the next position in the process. With proper coordination, a panel should be replaced in the floor immediately behind a panel being removed to pass through the process. Rotate positions periodically to maintain efficiency.

Personnel Positions :

- 1) Panel remover and replacer - Pulls panels from the floor and passes the panels to the panel holder operator and replaces panels into the floor after recarpeted.
- 2) Panel Holder Operator – Removes two pedestals from the panel and passes the panel to the carpet holder operator and passes the removed pedestals to the panel jig operator.
- 3) Carpet Holder Operator – Removes the two remaining pedestals from the panel and passes the pedestals to the panel jig operator and stacks old carpet for disposal.
- 4) Panel Jig Operator – Places new carpet into jig, removes waxed paper and presses the pedestals into the proper position and passes the completed panel to the replacer.
- 5) Perimeter Worker – Pulls carpet from perimeter and leaves perimeter In place.
- 6) Carpet Cutter – Cuts new carpet to fit existing perimeter.

Full Panel Replacement Procedures

- 1) Remove a full panel from the floor and place the panel in the panel holder.

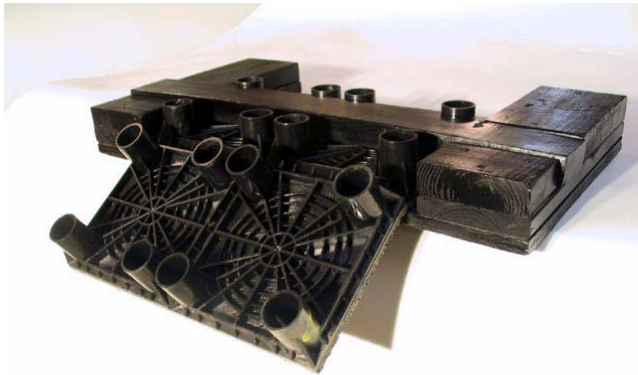

- 2) Place pedestal puller into pedestal legs of an exposed pedestal, pull downward and remove pedestal number 1 and repeat the procedure for pedestal number 2.

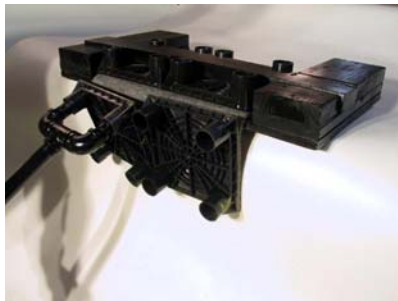

- 3) Remove panel from panel holder and place exposed carpet into carpet holder.

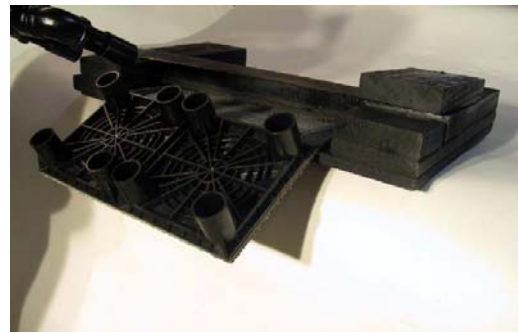
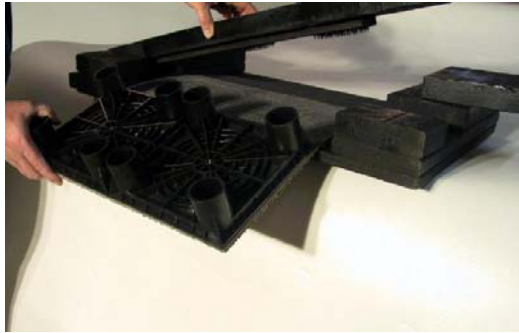

- 4) Place pedestal puller into pedestal legs of an exposed pedestal, pull downward and remove pedestal number 3 and repeat the procedure for pedestal number 4.

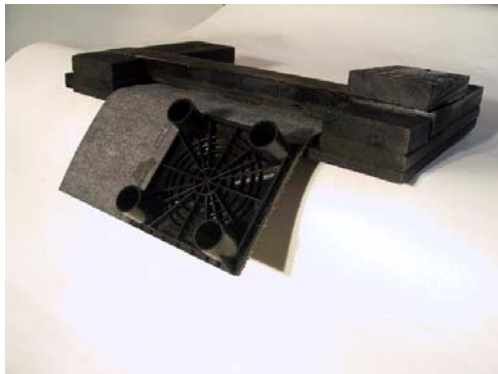
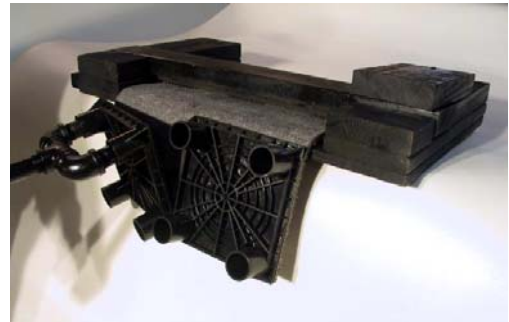
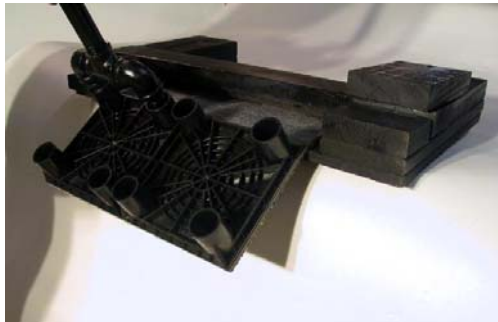

- 5) Place new pre-glued carpet tile face down into panel jig, remove paper backing, attach pedestals one by one, by pressing tightly into the corner of the jig.

Please Note: Be sure to place the directional arrows to the outside and align with the directional arrows on the carpet.

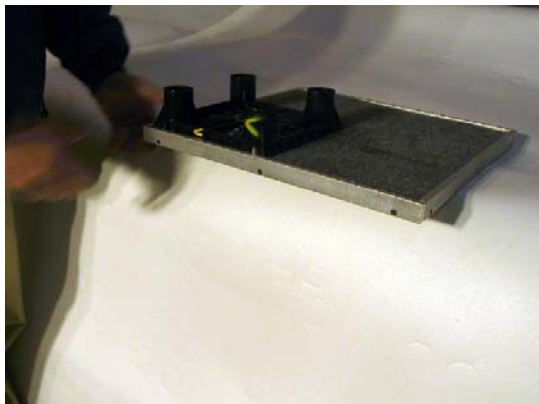
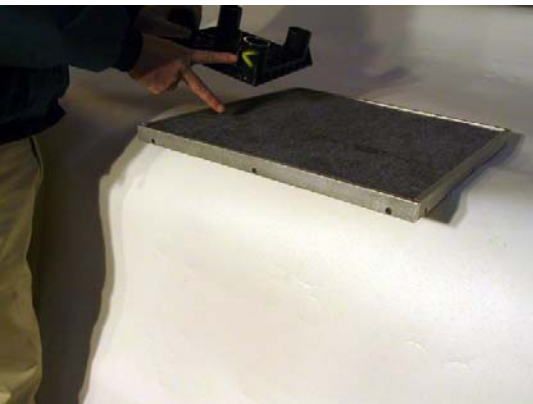
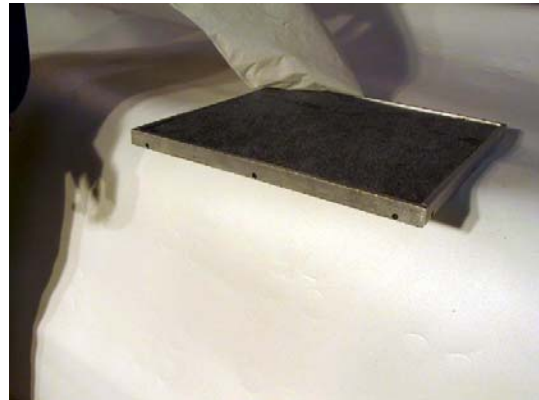

5) Replacement Procedures - Step 5 (Continued)

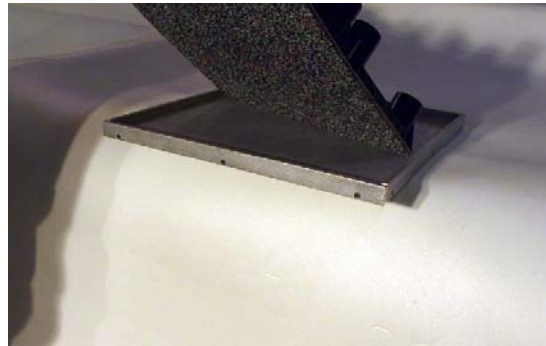
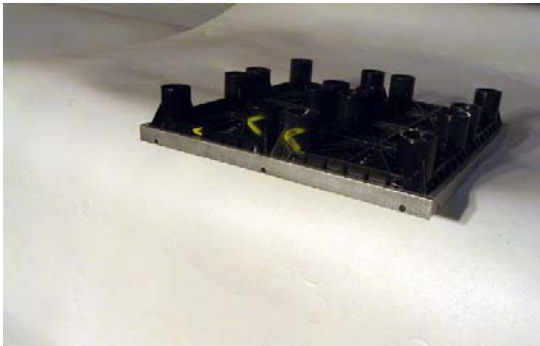
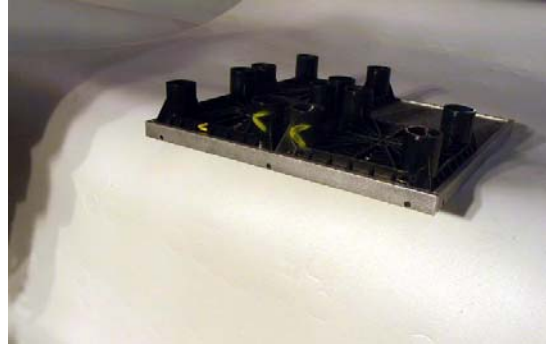
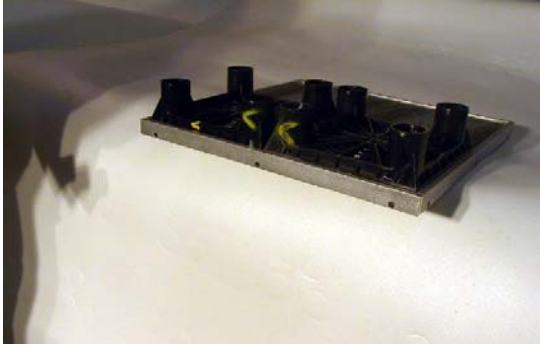

7) Replace the completed panel into its original position in the floor.

Full Panels with Power/Data Ports

- 1) Disconnect power or data from port and remove the panel from the floor.
Remove the port.



- 2) Follow regular procedures for carpet tile replacement.
- 3) The hole jig must be centered and pre-set in the drill press with the hole saw attached as shown below.

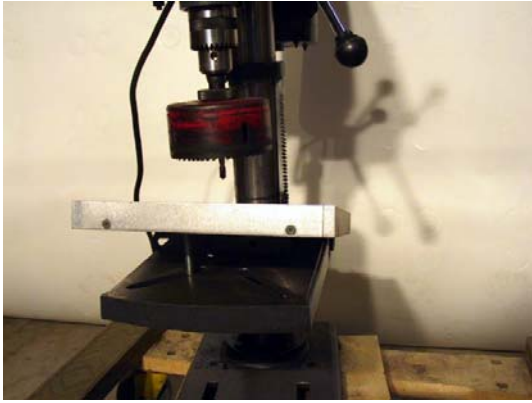

- 4) Place the ported corner of the panel into the hole jig and drill a 4" hole through the carpet tile.



- 5) Replace the port into the panel in the proper direction.
- 6) Reconnect the power and/or data and replace the panel in the proper location.

Perimeter Carpet Replacement

Perimeter panels are a small part of the installation and the carpet must be removed and replaced panel by panel by hand. The original carpet tile may be used as a template to cut the new carpet to fit.

Summary

Carpet replacement procedures and manpower requirements will be dictated by the size of the project and individual job site circumstances.

For sizable projects the assembly line process is the most cost effective and efficient way to accomplish the carpet tile replacement. Results will vary considerable given variations in conditions. It is estimated, that with this procedure in normal uninterrupted circumstances, a panel should be recarpeted and replaced in the floor at an average of one panel per minute or approximately 22 square feet per man hour.

OUTLET SERVICE & RELOCATION

General

The Powerflor Cable Management System provides for the relocation and change in service for all system, electrical and communication outlets. These changes typically can be accomplished very easily and quickly, without the need for specialized tools and without technical staff. The changes can be a simple change in an outlet's location, or can also include a change in the service to an outlet. The following procedures are recommended for performing these service changes.

Panel Removal & Replacement

An integral part of the relocation and / or service change of any outlet, includes the removal and replacement of the chaseway floor panels. The Powerflor system panels are not attached to each other or to the building structure. They are simply lifted up and out of their current location and can be replaced back into the system at any empty panel location.

- 1) Locate the panel containing the outlet / outlets you wish to service and remove the Powerport lid / lids.
- 2) Grasp the powerport and lift the panel out of the system. Once the carpet tile edges release from adjacent carpet edges, the panel easily lifts out of place. (see Pictures 14-1 & 14-2)

Please Note !! In some instances it is desirable to remove a panel that does not contain an outlet. In these instances, any flat bladed instrument (i.e. pen knife, putty knife, etc.) can be inserted into the seam between two panels, and by pushing down on the instrument, the panel comes up at its edge. (see Pictures 14-3, 14-4, & 14-5)

- 3) Removing adjacent panels in all directions is accomplished by simply grasping it's exposed edge and lifting out of place.
- 4) To return any panel to the system, simply place the panel back into any panel void. All full panels are interchangeable with each other, so any full panel location will receive any full panel. To maintain system flexibility you must replace panels maintaining the corner to corner panel locations.

Please Note !! When replacing any panel back into the system, you must maintain the carpet grain direction. Note the direction indicated by the yellow arrows on the side of the panel legs, and place the panel into the floor maintaining this direction for all other panels. (see Picture 14-6 & 14-7)

Also, care must be taken in assuring that the panel legs are not placed on any of the cabling underneath the panel. The leg impressions in the volara foam underlay will assist in panel location and cable placement. (see Pictures 14-8 & 14-9)

Picture 14-1



Picture 14-2



Picture 14-3



Picture 14-4



Picture 14-5



Picture 14-6



Picture 14-7

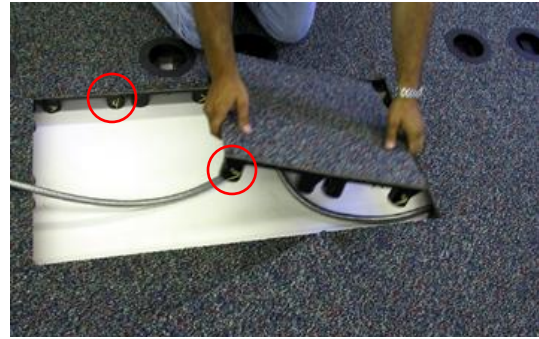

Picture 14-8

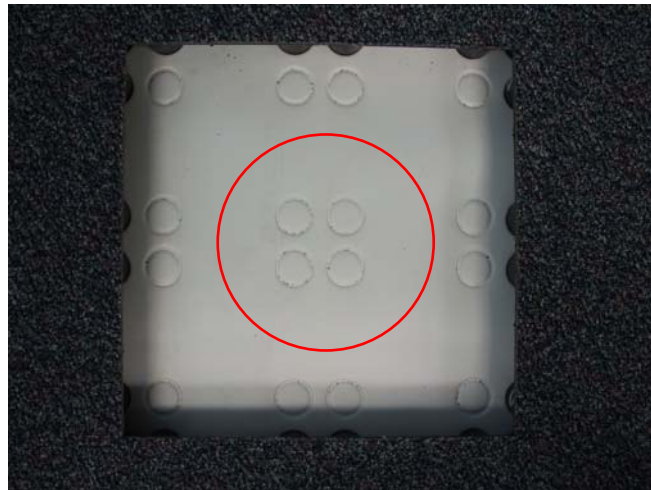

Picture 14-9

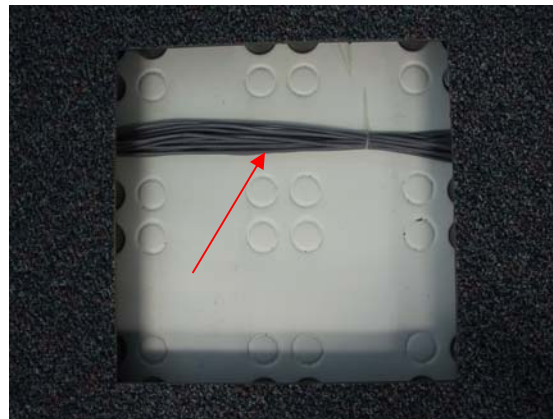

Electrical Outlet Relocation

Changing the location of an electrical outlet within the system.

- 1) Locate the panel that contains the electrical outlet you wish to relocate and remove the panel from the system as described previously.
- 2) Remove adjacent panels that cover the connecting cable / cables away from the panel / outlet to be relocated. (see Picture 14-10 & 14-11)
- 3) Enough panels should be removed to allow for the connecting cable / cables to be moved while maintaining the feed to the outlet being relocated.
- 4) Locate the panel with the outlet in it, to the new location, maintaining the corner to corner alignment of all panels. (see Pictures 14-12 & 14-13)
- 5) Adjust cable / cables to avoid the legs of the panels that cover them. (see Picture 14-14)
- 6) Replace all panels back into the system, as described previously. (see Picture 14-15)

The Powerflor system is designed to offer ample slack (approx. 20% of cable length) to allow for most outlet relocations. If your relocation requires more cable length than is available, disconnecting and reconnecting the cable / cables from the outlet is required.

When cables of additional length are required, they can be obtained from Powerflor. However, most system layouts involve cables of varying lengths. Typically as you are moving an outlet away from one point, you are moving towards another. You may wish to review the cable layout from the drawing prior to the change and plan on exchanging cable assemblies from other areas. This will allow for the relocation without new cable assemblies being required. If an exchange is made, it is important to maintain the color coding of the cable assemblies, and the power leg they are a part of.

Following are the recommended steps for this procedure.

- 1) After removing the panel with the outlet from the system, remove the outlet from the panel by releasing the two spring clips that hold it in place and pulling the electrical J Block from the powerport grommet. (see Picture 14-16)
- 2) This will expose the thumb clip that holds the cable assembly connector to the J Block. Lift this thumb clip and pull the cable assembly from the J Block. (see Picture 14-17)
- 3) After the appropriate cable / cables have been obtained or located, the cable assemblies plug into the J Block as required.

Please Note !!! When plugging the cable assembly into the J Block, care must be taken to align the matching keyways that are located on the internal side of the cable connector and external J Block plug area. (see Picture 14-18)

Picture 14-10



Picture 14-11



Picture 14-12



Picture 14-13

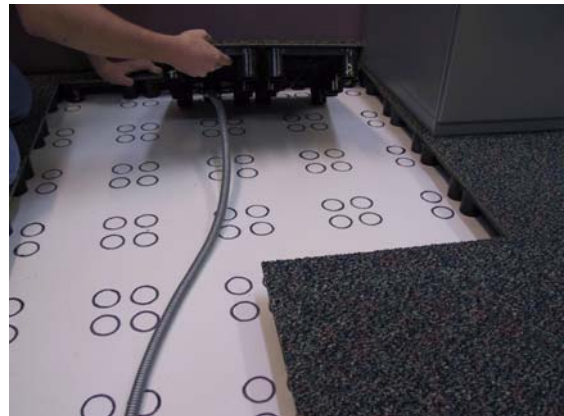

Picture 14-14



Picture 14-15



Picture 14-16

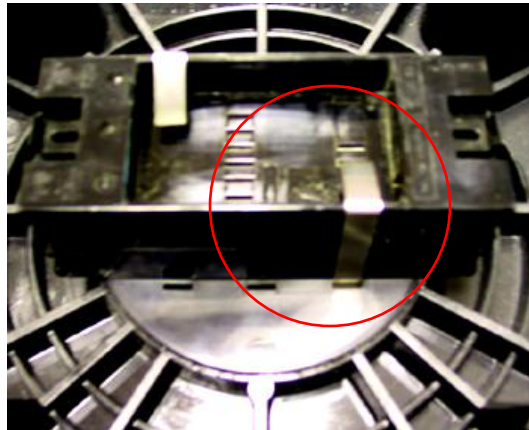

Picture 14-17

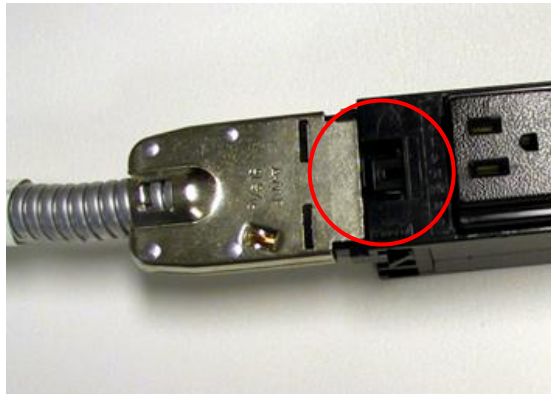

Picture 14-18

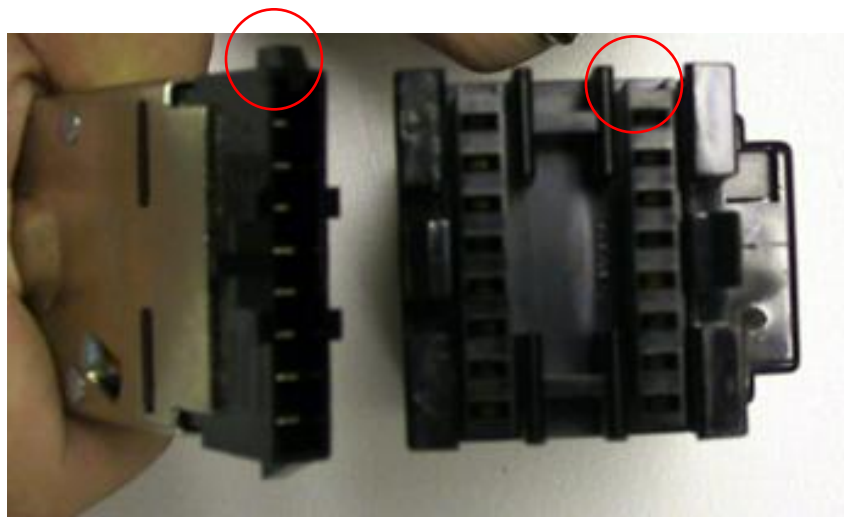

Electrical Outlet Service Change

Changing the circuit that powers an electrical outlet. The Powerflor electrical system provides four 20 ampere circuits, per power leg. Each leg is color coded with marking tape at each cable assembly end (see Picture 14-19). The circuit is identified on the outlet insert face (i.e. 1, 2, 3, or 4 for standard systems) and (i.e. 1G, 2G, 3G or 4G for isolated ground systems). (see Picture 14-20)

- 1) Locate the panel that contains the electrical outlet you wish to change the circuit feed for and remove the panel from the system as described previously.
- 2) After removing the panel with the outlet from the system, remove the outlet from the panel by releasing the two spring clips that hold it in place and pulling the electrical J Block from the powerport. (see Picture 14-16)
- 3) Remove the duplex outlet insert from the J Block by depressing the two tabs located on either end of the insert and unplugging the insert from the J Block. (see Picture 14-21)
- 4) Place the new insert with the circuit designation desired, aligning the tabs into the J Block, and push until it snaps into place.
- 5) Re-connect all cable assemblies and re-mount into the powerport.
- 6) Place panel into system as described previously.

Please Note !!!

When making any changes to the electrical system, make certain that the power is turned off to all circuits providing power to the system.

Review the project drawing and any changes to the system that have been previously performed. Note all changes you are making on the drawing.

Maintain the color coding of all electrical legs in the system.

Great care needs to be taken to assure that you do not plug two or more legs of power into each other !!!!

Picture 14-19



Picture 14-20



Picture 14-21

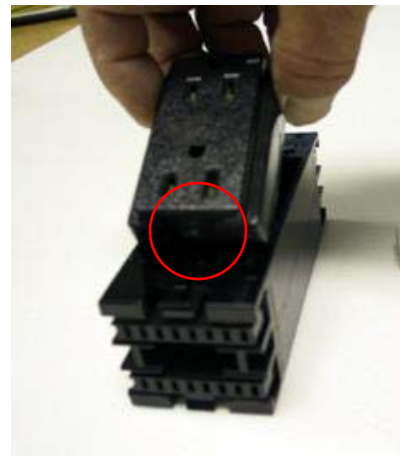

Communication Outlets / Relocation

Changing the location of a communication outlet within the system.

- 1) Locate the panel that contains the communication outlet you wish to relocate and remove the panel from the system as described previously.
- 2) Remove adjacent panels that cover the communication cable away from the panel / outlet to be relocated. (see Pictures 14-22 & 14-23)
- 3) Enough panels should be removed to allow for the communication cable to be moved while maintaining it's connection to the outlet being relocated.
- 4) Locate the panel with the outlet in it, to the new location, maintaining the corner to corner alignment of all panels. (see Picture 14-24)
- 5) Adjust cable to avoid the legs of the panels that cover them. (see Pictures 14-25, 14-26 & 14-27)
- 6) Replace all panels back into the system, as described previously.

The Powerflor system is designed to offer ample slack to allow for most outlet relocations. Standard pre-terminated communication cables are provided in 25', 50', 75', 100', and 150' lengths. Review the communication cable layout as shown on the project drawing, prior to the change, to determine if new cables are required. When cables of additional length are required, they can be obtained from Powerflor.

If your relocation requires more cable length than is available, disconnecting the existing cable and reconnecting the new cable from the outlet is required.

Following are the recommended steps for this procedure.

- 1) After removing the panel with the outlet from the system, turn the panel over and place it upside down on the floor, exposing the back of the communication outlet. (see Picture 14-28)
- 2) This will expose the mod-edge connector that connects the cable assembly to the communication outlet. Un-screw the small Phillips head screw that holds the mod-edge connector in place and pull the cable assembly from the back of the outlet. (see Picture 14-29)
- 2) Remove adjacent panels that cover the cable back to the wiring closet and unplug the cable from the connection device (i.e. patch panel, hub, etc.) (see Picture 14-30)
- 4) After the new cable has been obtained or located, plug the RJ45 connector end into the appropriate location in the wiring closet, place the cable into the chaseway floor to the new outlet location, and connect to back of communication outlet.
- 5) Replace all chaseway panels back into the system to complete the change. (see Picture 14-31)

Picture 14-22



Picture 14-23



Picture 14-24



Picture 14-25

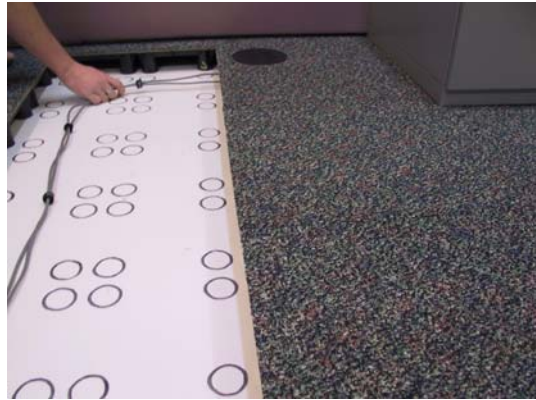

Picture 14-26

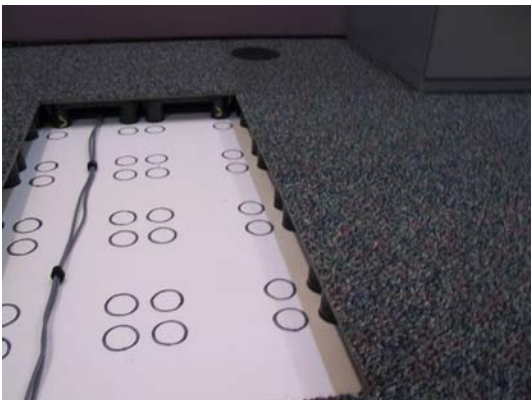

Picture 14-27



Picture 14-28

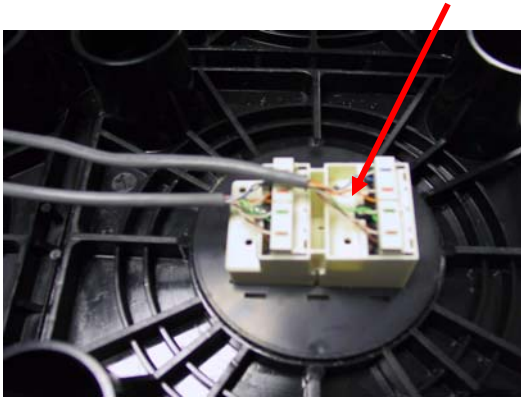

Picture 14-29



Picture 14-30



Picture 14-31

