

UC-90 CRIMPING TOOL

DRWG NO.	DESCRIPTION	PART NO.
1	PISTON HOUSING REMOTE	1-F-004
3	PISTON SHAFT	3-003
5	PISTON LOCK PLATE	5-004
14	END CAP	14-004
15A	O'RING PISTON SEAL	15A-004*
16	O'RING (2 required)	16-003-K10*
17	O'RING	17-004-K10*
18	O'RING	18-01*
29	PISTON WASHER	24-01
35	O'RING	35-003-K10*
36	PISTON SEAL HOLDER	36-004
37	MOUNT SCREW (3 required)	37-003-K10
38	JAW ASSEMBLY SCREW (4 required)	4-24A
39	JAW HOUSING	4-2B
40	LOCK WASHER (4 required)	4-10A
41	SIDE PLATE (set of 2)	4-30A
42	SNAP RING (4 required)	4-7A
43	PIVOT PIN (2 required)	4-9A
44	JAW ROLLER (2 required)	4-19-525-K2
45	ROLLER PIN (2 required)	4-20A
46	JAWS (sold as set only)	RUC-9RL
47	INSERT HOLDING SCREW (2 required)	38-RU9
48	INTERNAL JAW SPRING	4-8A
49	CAM	25-S
50	SET SCREW	4-3A

*INCLUDED IN PARTS KIT – #004-KIT
 AVAILABLE ACCESSORY – UC-L – Locator shelf

Not shown but included with UC-90 unit – two (2) #102-5 air hoses, one (1) A-202-4 bench stand, one (1) #105 footswitch



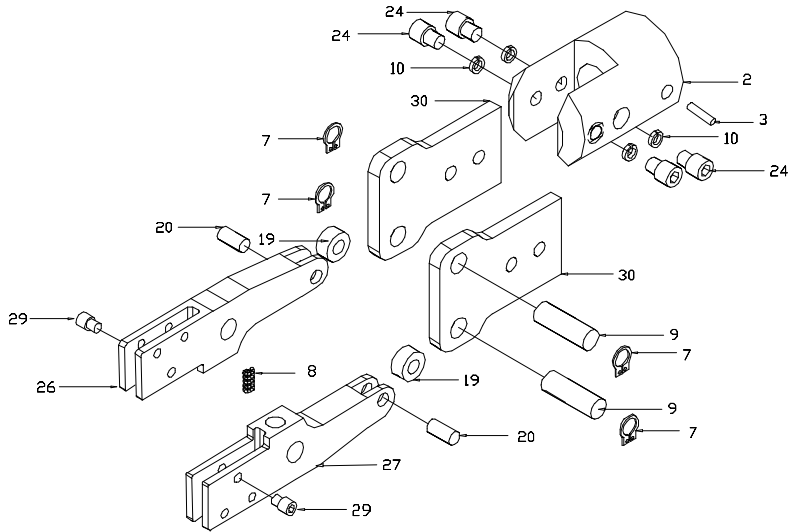

PART LIST FOR THE UC-9 JAW AND HOUSING
PARTS PRICE LIST

DRW. NO.	DESCRIPTION	PART NO.
2	JAW HOUSING FOR A-4 JAWS	4-2B
3	SET SCREW	4-3A
7	SNAP RING (4 REQUIRED)	4-7A
8	INTERNAL JAW SPRING	4-8A
9	PIVOT PIN (2 REQUIRED)	4-9A
10	LOCK WASHER (4 REQUIRED)	4-10A
19	JAW ROLLER (2 REQUIRED)	4-19-525
20	ROLLER PIN (2 REQUIRED)	4-20A
24	JAW ASSEMBLY SCREW (4 REQUIRED)	4-24A
26	JAW RIGHT	RUC-9R
27	JAW LEFT	RUC-9L
29	INSERT HOLDING SCREW (2 REQUIRED)	38-RU9
30	SIDE PLATE (SET OF TWO)	4-30A

Notes:

**RUC-9 REQUIRES 25-S CAM ON POWER PACK
 PART #26 & 27 ARE NOT SOLD SEPARATE**

